

FARM-FLEET



2014 CATALOGUE

COMMERCIAL

LANDSCAPING

CONSTRUCTION

LAWN & GARDEN

AGRICULTURE

FORESTRY

INDEX

- Aerators 39,71,72,73
ATV Box Scrapers 100
ATV Carts 64-66
ATV Discs 98-99
ATV Land Plane 99
ATV Landscape Rake 100
ATV Scraper Blades 100
ATV Seeder 81,89
ATV Snowblower 42
ATV Spreader
. 77,79,80-81,89
Bale Forks & Spears
. 128-134
Box Scrapers 52-57
Canopies 152-153
Carts 64-66
Cement Mixers 63
Chain Harrows 101
Chipper/Shredders 116
Core Aerators 39,72
Crane Boom 139
De-Thatcher 67,71
Discs (also see ATV Discs)
. 146-151
Engine Driven Mowers
. 6-7,17-18
Engine Driven Snowblower
. 42
Engine Driven Tillers 31
Estate Sprayers 92-96
Fertilizer Spreaders 76-91
Finishing Mowers 17-25
Flail Mowers 26-29
Flex Mower 23-25
Foam Markers 97
Forestry Grapple 117-119
Grapple Bucket 121-123
Grapple Rake 118-119
Harrows 101
Hay Handling 128-134
Hay Rakes 126-127
Hydraulic Top Link 154
Land Plane 59
Landscape Rakes 60-62
Lawn Rollers 71,74,75
Lawn Sweepers 68-69
Lawn Vac 70
Log Grapples
. 118,122-123
Log Splitters 112-114
Logging Winches 110-111
Manure Forks 123
Manure Spreaders 103
Mixers (Cement) 63
Moldboard Plow 136
Mowers 15-29
Offset Discs 147,150 -151
Overseeder 40-41,83
Packers 145
Pallet Forks 124-125, 139
Plows 136-138
Post Drivers 142-143
Post Hole Diggers 140-141
Potato Planter/Hiller/Digger
. 135
Powered Landscape Rake
. 60-61
Pulverizers 38
Quick Attach Brackets
. 121, 155
Quick Hitches 3 Pt. 154
Rakes (Grapple) 118-119
Rakes (Hay) 126-127
Rakes (Landscape) 60-62

INDEX

Rakes (Rock)	105
Rippers	137-138
Rock Buckets	120
Rock Rakes	105
Rollers	71,74-75
Rotary Broom . . .	156-157
Rotary Cutters	6-14
Rotary Tillers	31-37
Scraper Blades	44-47
Sickle Bar Mower	15
Skid Steer Adaptor . . .	155
Skid Steer Rotary Brooms	156
Skid Steer Blades . . .	48-49
Skid Steer Grapple	119-122
Snow Blades	43,48-50
Snowblowers	42-43
Spiker / Aerator	73,75
Spray Foam Markers. . .	97
Sprayers	92-96
Spreaders	76-91
Stone Forks	120
String Trimmer	16
Stump Grinder	115
Sub-Soilers	137-138
Sweepers	68-69
Tillers	31-37
Tractor Canopies .	152-153
Tree Cutter	107
Tree Saw	106
Tree Shears	108-109
Utility Carrier	139
Vacuums	70
Winches	110-111



Aerators	71-73
ATV Dump Carts . . .	64,66
ATV Snowblower	42
Carts	64,66
Core Aerators	72
De-Thatcher	67
Fertilizer Spreaders	76,77,80,82
Lawn Rollers	71,74
Lawn Sweepers	69
Lawn Vac	70
Rollers	71,74
Smart Link Attachments	71
Snowblowers/Snow Plows	42-43
Spike Aerators	73
Spreaders	76,77,80,82
Sweepers	69
Tillers	31
Tractor Carts	64,66
Vacuums	70

**INDEX CONTINUED
ON NEXT PAGE.....**



We reserve the right to correct printing errors, limit quantities or make merchandise substitutions. Pictures are representative only and may vary from actual product. Prices subject to change without notice. Prices maybe subject to additional freight & set-up charges. Not all products stocked at all locations. F.O.B. St. Marys, Ontario unless otherwise stated.

TABLE OF CONTENTS



www.amazone.de

Spreaders 90-91

BARE-Co

www.bare-co.com

Tractor Canopies 152-153



www.befco.com

Aerator/Overseeder Green Rite .	41
Baby Hop Ground Driven	84
"Chipper 6""	116
Core Aerators	39
Finishing Mowers	
C30 Series	20
C50 Series	21
C70 Series	22
Flex Mowers	23-25
Engine Driven Finish Mower . .	18
Flail Mowers	
H40 Series, Hurricane	26
H70 Series, Hurricane	27
H80 Series, Hurricane	28
Hay rakes	127
Overseeders	40-41
Rotary Tillers	
T30 Series	33
T40 Series	34
T50 Series	35
T60 Series	36
T70 Series	37
Soil Pulverizers	38
Spreaders	84,85,87
Turbo Hop Spreader	87



www.brownmanufacturing.com

Rotary Cutters HD & ExtraHD 10,12	
Rotary Cutters Tree Cutter	14
Tree Saw	106



Sickle Bar Mower 15



www.fimcoindustries.com

Dump Carts	65
Estate Sprayers	92-96
Manure Spreader	103
Spreaders - Broadcast	81,88

Fransgård

www.fransgard.dk

Accessories - Winch	111
Forestry Grapple	117
Logging Winches	110
Rake, Hay	126
Rotary Cutter Chain Mulcher . . .	13

Hackett Harrows

Chain Harrows 101



www.shoule.com

Grapple Rake	121
Tree Shears	108-109
Rock Buckets	120
Rock Rakes	105



www.howseimplement.com

Box Scrapers	52
Finishing Mowers	19
Moldboard Plow 3 Pt.	136
Rotary Cutters	8,9,11
Scraper Blades	44-45

TABLE OF CONTENTS



www.monroetufline.com

42 Series Discs	150-151
ATV	
Box Scrapers	100
Discs Harrows	98-99
Land Plane	99
Landscape Rake	100
Scraper Blade	100
3 Pt. Box Scraper	53-56
Pull Type Box Scraper	57
Land Plane	59
Offset Discs	147,150-151
Packers 3 Pt.	145
Scraper Blades	46
Sub-Soilers	138
THE Series	146
TLO Series	147
TW6 Series	148-149



ROTOMEC

Rotary Tillers	32
--------------------------	----



Finishing Mower	17
Rotary Cutter	6-7
String Trimmer	16



Logsplitters	112-114
------------------------	---------



Spray Foam Markers	97
------------------------------	----



WORKSAVER

www.worksaver.com

ATV Seeder Spreader	89
Cement Mixers	63
Crane Boom	139
Euro to Skid Steer Adaptor	155
Grapples	118-119, 122
Hay Handling Attachments	128-134
Hydraulic Top Link	154
Landscape Rakes	62
Manure Forks	123
Pallet Forks	124-125
Post Drivers 3Pt. & Skid Steer	142-143
Powered Landscape Rake	60-61
Post Hole Diggers	140-141
Quick Hitches 3 Pt.	154
Rippers Single Shank	137
Rotary Broom	156-157
Snow Blades	48-50
Stump Grinder	115
Tree Clippers	107
Utility Carrier	139
Weld On Euro/global ALO	
Quick Attach	155



Core Aerators	72
Lawn Sweepers	68
Spiker Spreader	83
Spreader - Broadcast	78-79
Sweepers	68
Roller/Spiker	75



We reserve the right to correct printing errors, limit quantities or make merchandise substitutions. Pictures are representative only and may vary from actual product. Prices subject to change without notice. Prices maybe subject to additional freight & set-up charges. Not all products stocked at all locations. F.O.B. St. Marys, Ontario unless otherwise stated.

ROTARY CUTTER

Engine Driven

Walk Behind



The SWISHER walk behind Trailcutter mower is perfect for cutting trails through the woods and clearing fields and ditches. It will clear the densest undergrowth and saplings up to 1-1/2" in diameter. This self-propelled walk-behind features a 11-1/2 HP Briggs & Stratton Engine and a heavy duty fabricated deck. It's single, fixed hardened steel blade cuts through brush and saplings with ease. The blade is enclosed for maximum safety. Front and side safety deflectors protect against flying debris. Handlebar mounted controls are easily accessed for total control and safety. Proper safety attire and eye protection should be used. Large chevron tread pneumatic tires roll easily over the roughest terrain for smooth cutting in all conditions. A four speed transmission is great for climbing or cruising and the reverse gear is handy for easy backing up.

- * **24" Cutting Width**
- * **11.5 HP B&S Engine**
- * **Manual recoil start**
- * **4 Speed transmission with neutral & reverse**
- * **Tires two 4.80 x 8 pneumatic tires**
- * **One H.D. hardened steel fixed blade**
- * **Up to 1-1/2" sapling cutting diameter**
- * **Cutting height, Variable**
- * **.7 US gallon fuel capacity**
- * **Handlebar drive controls**
- * **Handlebar manual PTO clutch**
- * **Proper Safety Attire is recommended**

MODEL	DESCRIPTION	WEIGHT	LIST PRICE
WB11524BS	11.5 HP, 24" walk behind Rotary Cutter	288 lbs.	\$2399

ROTARY CUTTER

Engine Driven

Pull Type



SWISHER rough cut Trailcutter is perfect for any big mowing job. Backed by the power of 60 + years of design experience, this mower is designed to dramatically reduce mowing time. The SWISHER Trailcutter easily attaches to your ATV, UTV or lawn tractor. These models will cut saplings up to 3" in diameter and thick brush with two heavy duty swinging blades. A convenient single point cutting height adjustment with a 4" range on 44" model and 2.5" - 7" on 52" model. The remote control operator console on the 52" model lets you safely engage and disengage the mower blades from your ATV or tractor seat.

- * Offsets, left/right/center articulating
- * Two 4.00 x 8" pneumatic tires with sealant on 44"
- * Four 13x5x6 puncture resistant semi-pneumatic tires on 52"
- * Two H.D. hardened steel swinging blades
- * Up to 3" sapling cutting diameter
- * 2.5 US gallon fuel capacity
- * 44" clevis/pin type hitch
- * 52" 2" trailer hitch ball coupler
- * 12V electric start
- * 44" manual PTO Clutch
- * 52" electric PTO Clutch
- * Remote Operator Control Console
- * 12V battery EXTRA (not included)

MODEL	DESCRIPTION	WEIGHT	LIST PRICE
RC14544BS	44", 14.5 HP B&S engine Electric start, 2 wheel	400 lbs.	\$2869
RC17552BS	52", 17.5 HP B&S engine Electric start, 4 wheel	587 lbs.	\$4169

ROTARY CUTTERS

3 Pt. Hitch PTO



Unit Shown With Optional Safety Chain

These affordable rotary cutters built by **HOWSE** Implement Company are ideal for the cutting of grass and pasture land. These models feature segmented rubber tires and 1/2" shear pin protection.

- * Cat I, 3 Pt hitch
- * Shearpin PTO with shield
- * Saucer shaped blade carrier (Stump Jumper)
- * 12 ga. steel deck with 7-1/2" sides
- * Heavy angle iron frame
- * Single 4" x 15" solid laminated rubber tire with cast wheel hub
- * Optional safety protective chains available

MODEL	MAXIMUM PTO HP	CUTTING WIDTH	WEIGHT	LIST PRICE
400	45 HP	48" / 4'	518 lbs.	\$999
500	45 HP	60" / 5'	579 lbs.	\$1049
601S	55 HP	72" / 6'	710 lbs.	\$1369

The manufacturer highly recommends the use of optional safety chains.

OPTIONS:

MODEL	DESCRIPTION	LIST PRICE
K0400C	48" / 4' Safety chain kit	\$289
K0500C	60" / 5' Safety chain kit	\$325
K0600C	72" / 6' Safety chain kit	\$379

ROTARY CUTTERS

Medium Duty

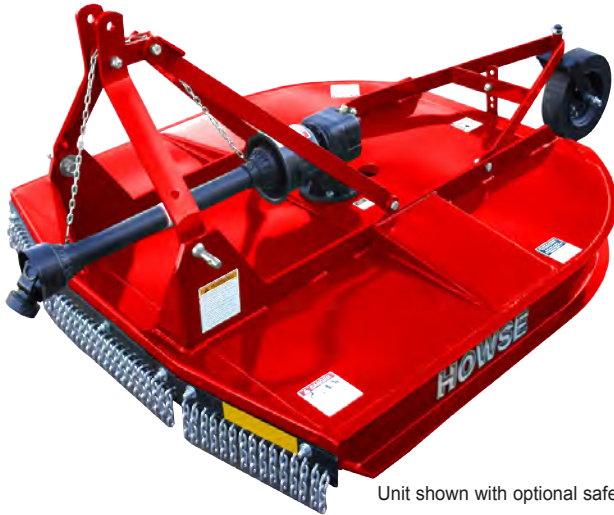

Unit shown with optional safety chains

These rotary cutters built by HOWSE Implement are available in three sizes, 5', 6' & 7'. 5' & 6' models come with a 75 HP rated gearbox and the 7' model comes with a 150 HP rated gearbox. The front of the 5' & 6' cutter is tapered to give more tractor tire clearance. A torque limiter slip clutch PTO is standard on all three models. Slotted top link mounting hole allows for free float of the 3 Pt. hitch.

- * Cat I, 3 Pt hitch
- * Slip clutch PTO with shield
- * 75 HP rated gearbox, 5' & 6'
- * 150 HP rated gearbox 7'
- * Heavy C channel sides
- * 10 ga. steel deck with 7" sides
- * Tapered front, rounded back on 5' & 6'
- * Single 4" x 15" solid laminated rubber tire with cast wheel hub
- * Free floating 3Pt. top link
- * Continuously welded deck to side wall for greater strength
- * Optional front and rear safety chains are available
- * 7' Model comes with dual 4" x 15" laminated tire with heavy bearing type wheel hub

MODEL	MAXIMUM PTO HP	CUTTING WIDTH	WEIGHT	LIST PRICE
505T-6	65 HP	60" / 5'	669 lbs.	\$1499
606T	65 HP	72" / 6'	800 lbs.	\$1699
CRB842	85 HP	84" / 7'	1308 lbs.	\$2699

The manufacturer highly recommends the use of optional safety chains.

OPTIONS:

MODEL	DESCRIPTION	LIST PRICE
K0505C	60" / 5' Safety chain kit	\$279
K0606C	72" / 6' Safety chain kit	\$325
K0RB84C	84" / 7' Safety chain kit	\$425

ROTARY CUTTERS 410 SERIES HEAVY DUTY 3 Pt. HITCH PTO



415



417

With over 50 years of innovative design and production, BROWN Mfg. has set the standard for heavy duty rotary cutters. The 410 series rotary cutter comes with a 130 HP rated gearbox, with limited 5 year warranty. Available in three sizes, 5', 6' and 7' with a slip-clutch PTO Shaft this heavy duty cutter is tough enough to cut heavy brush and trees up to 2" in diameter.

- * Deck Design, round back, reinforced
- * Deck Construction, all welded 7 gauge (3/16") steel
- * 130 HP rated gearbox, limited 5 year warranty
- * Cat. 5 Slip-clutch PTO shaft on 5' & 6' models
- * Cat. 6 Slip-clutch PTO shaft on 7' model
- * Laminated solid rubber tail wheels
- * 5' & 6' single tail wheel, 7' dual tail wheel
- * 5' & 6' Cat. I/II clevis style 3 Pt. hitch
- * 7' Cat. II clevis style 3 Pt. Hitch
- * Stump Jumper 1/4" bow tie with 1" x 5" solid bar
- * 1/2" x 4" heat treated/up draft type blades
- * Replaceable slides
- * Replaceable front rubber deflector
- * Optional chain guards available

MODEL	DESCRIPTION	WEIGHT	LIST PRICE
415	5' Rotary Cutter, Single Tail Wheel	900 lbs.	\$2879
416	6' Rotary Cutter, Single Tail Wheel	1060 lbs.	\$3379
417	7' Rotary Cutter, Dual Tail Wheel	1375 lbs.	\$4829

OPTIONS:

DESCRIPTION	WEIGHT	LIST PRICE
5' Front Chain Guard	53 lbs.	\$275
5' Rear Chain Guard	21 lbs	\$225
6' Front Chain Guard	57 lbs	\$289
6' Rear Chain Guard	37 lbs	\$245
7' Front Chain Guard	67 lbs	\$309
7' Rear Chain Guard	42 lbs	\$309

ROTARY CUTTER

Medium Duty 3 Pt.



Unit shown with optional safety chains

- * Cat I, 3 Pt hitch
- * Slip clutch PTO with shield
- * 100 HP rated side gearboxes
- * 150 HP rated center T gearbox
- * Saucer shaped blade carrier (Stump Jumper)
- * 4 Free swinging blades
- * 12 ga. steel deck with 7-1/2" sides
- * Tapered front, rounded back
- * Dual 4" x 15" solid laminted rubber tire with cast tapered bearing wheel hub
- * Optional safety protective chains available

MODEL	MAXIMUM PTO HP	CUTTING WIDTH	WEIGHT	LIST PRICE
C808HN	75 HP	96" / 8'	1345 lbs.	\$3599

The manufacturer highly recommends the use of optional safety chains.

OPTIONS:

MODEL	DESCRIPTION	LIST PRICE
KO808C	96" / 8' Safety chain kit front & rear	\$449

ROTARY CUTTERS EXTRA HEAVY DUTY 3 Pt. HITCH PTO



Model 684 shown with dual wheels

With over 50 years of innovative design and production, BROWN Mfg. has set the standard for heavy duty rotary cutters. The 600 series rotary cutter comes with a 145 HP rated gearbox, with limited 5 year warranty. Available in two sizes, 6' and 7' with a slip-clutch PTO Shaft, this heavy duty brush cutter is tough enough to cut heavy brush and trees up to 4" in diameter.

- * Deck Construction, all welded
1/4" thick, steel plate
- * 145 HP rated gearbox, 1:1.5 ratio
- * Available in 540 RPM & 1000 RPM
- * Cat. 8 Slip-clutch PTO shaft
- * Laminated solid rubber tail wheels 5.00 x 8
- * Tail wheel: Single 6', Dual 7'
- * Cat. II clevis style with flex link
3 Pt. hitch
- * 1-1/4" - 6' & 1" - 7' solid blade bar
- * 5/8" x 6" Blades(Ultra-Kor tm)
- * Replaceable slides 5/8" x 2 1/2"
- * Reinforced rear deflector shield
- * Standard front safety chain
guards

MODEL	DESCRIPTION	WEIGHT	LIST PRICE
672HD	6' Brush Cutter 540 RPM	1720 lbs	\$7239
672HD-1	6' Brush Cutter 1000 RPM	1720 lbs	\$7239
684	7' Brush Cutter 540 RPM	2240 lbs	\$8279
684-1	7' Brush Cutter 1000 RPM	2240 lbs	\$8279

ROTARY CUTTER CHAIN MULCHER OFFSET

Fransgård



New from Fransgård, a 3 Pt. hitch, 5' offset rotary cutter, 540 RPM PTO with a unique cutting system consisting of four 3/8" x 30" long chains used as the cutting/mulching blades. This unit has the ability to cut or mulch material up to 4" in diameter, offset from the tractor. For cutting ditch banks, around ponds, fence lines etc.

- * **540 RPM PTO**
- * **PTO Shaft with overrunning clutch**
- * **5' cutting width**
- * **Cutting capacity up to 4"**
- * **Cutting chains 4 x 3/8" x 30" long, hardened**
- * **Rear Safety Guard**
- * **Adjustable hydraulic offset capabilities up to 47"**
- * **Offset overload protection**
- * **Cat II 3 Pt. hitch**
- * **Triple banded v-belt with automatic belt tightner**
- * **Requires two sets of hydraulic remotes**
- * **Includes hydraulic hoses**
- * **Minimum 45 HP required**
- * **Range of cutting head movement (degrees) 35 down/90 up**

MODEL	DESCRIPTION	WEIGHT	LIST PRICE
FKR150	5' PTO Offset Rotary Cutter	1797 lbs	\$16,940

ROTARY CUTTER TREE CUTTER



The BROWN Mfg. 3 Pt. hitch Tree Cutter can give you the high performance and ability you expect from a machine of this quality. With either an open deck or the versatility of a folding deck unit you can cut and mulch trees , up to 8" diameter.

Model Price	TCO-2505C \$8,999	TCO-2605C \$9,739	TCO-2625C \$11,150	TCF-2605 \$10,589	TCF-2625 \$12,530
Model/RPM	Open Deck 540 RPM	Open Deck 540 RPM	Open Deck 540 RPM	Folding Deck 540 RPM	Folding Deck 540 RPM
Model Price	TCO-2500C \$8,999	TCO-2600C \$9,739	TCO-2620C \$11,150	TCF-2600 \$10,589	TCF-2620 \$12,530
Model/RPM	Open Deck 1000 RPM	Open Deck 1000 RPM	Open Deck 1000 RPM	Folding Deck 1000 RPM	Folding Deck 1000 RPM
Cutting Width	60"	72"	72"	72"	72"
PTO	Over-running 4 Disc Slip Clutch PTO				
Frame	3 x 3 x 1/4" Tubing	3 x 3 x 1/4" Tubing	3 x 3 x 1/4" Tubing	3 x 3 x 1/4" Tubing	3 x 3 x 1/4" Tubing
Deck	3/16" Plate Reinforced	Reinforced Double 1/4" plate to 1/2" total	Reinforced Double 1/4" plate to 1/2" total	Reinforced Double 1/4" plate to 1/2" total	Reinforced Double 1/4" plate to 1/2" total
Weight	1,700 Lbs.	2,200 Lbs.	2,350 Lbs.	2,500 Lbs.	2,600 Lbs.
Rear Guard / Rear Deck	2 Coil springs, collapsible push bar type	2 Coil springs, collapsible push bar type	2 Coil springs, collapsible push bar type	Twin folding Hydraulic rear section	Twin folding Hydraulic rear section
Gear Box	145 HP	145 HP	165 HP	145 HP	165 HP
H.P	50 to 90	60 to 90	70 to 100	70 to 90	80 to 100
Material Size	6" Maximum	6" Maximum	8" Maximum	6" Maximum	8" Maximum

SICKLE BAR MOWERS



**AGRICULTURAL
MACHINERY**



For tractors from 20 to 75 HP, the double action sickle bar mowers are Category I/II 3 Pt. hitch mounted. Units come with a safety breakaway bar that helps protect the cutter from obstructions in the field. Units come with a second sickle cutting knife. All units are equipped with a hydraulic lift on the cutter bar, single acting, tractor must be equipped with rear remote hydraulic couplers.

- * **HP Requirements: 20-75, 540 RPM**
- * **Double action sickle bar**
- * **Adjustable 3 Pt. hitch**
- * **Safety release**
- * **3 Pt. linkage, Cat. 1 and 2**
- * **Extra blade and chain with hook**
- * **Transport blade protection**
- * **Hydraulic lift system**
- * **Heavy duty shielded PTO shaft (1-3/8" ASAE Cat. 4)**
- * **Cuts at 45° up and 45° down**
- * **Belt Driven**
- * **Hydraulic Lift Cutter bar**

MODEL	CUTTING WIDTH	LIFT TYPE	WEIGHT	LIST PRICE
SBM006	6' / 72"	Hydraulic	576 lbs.	\$4895
SBM007	7' / 84"	Hydraulic	600 lbs.	\$5169
SBM008	8' / 96"	Hydraulic	648 lbs.	\$5659
SBM009	9' / 108"	Hydraulic	731 lbs.	\$6259

STRING TRIMMER

Engine Driven

Walk Behind



The SWISHER walk-behind string trimmer is an ideal back-saving alternative to heavy hand-held gas trimmers. The trimmer's extra wide 22" cutting swath rivals that of most lawnmowers, while its user-friendly design offers unsurpassed precision trimming performance. The trimmer features 13.75" wheels for plenty of clearance and smooth rolling over rough terrain. The trimmer line is easily replaced without the use of tools

- * **6.75 HP 190CC Briggs & Stratton Engine**
- * **Offset fixed left**
- * **Two 13.75" solid tires**
- * **Trimmer head (4).155" strings**
- * **.25 US gallon fuel capacity**
- * **Trimmer head disengages with engine running**

MODEL	DESCRIPTION	WEIGHT	LIST PRICE
STS67522BS	6.75 HP, walk behind String trimmer	74 lbs.	\$579

OPTIONS:

MODEL	DESCRIPTION	LIST PRICE
P3618	36 pack, 18" .155 trimmer line	\$15

FINISHING MOWER

Engine Driven

Pull Type



SWISHER finish cut Trailmower is perfect for any large area of grass to be mowed. Backed by the power of 60 + years of design experience, this mower is designed to dramatically reduce mowing time. The SWISHER Trailmower easily attaches to your ATV, UTV or lawn tractor to cut large lawns or park areas. This trailmower is powered by a 14.5 HP Briggs & Stratton engine and gives your lawn a manicured look. A 60" side-discharge fabricated cutting deck cuts a wide swath and spreads the grass out to avoid choking. The true floating deck reduces scalping for professional mowing results, even on tricky terrain. This mower is equipped with a 12 volt key starter (12V battery not included). A universal articulating hitch attaches to any pin hitch system and lets the mower maneuver easily behind the towing vehicle.

- * 14.5 HP Briggs & Stratton Engine
- * Offset hitch, left/right/center articulating
- * Tires four 13x5x6 pneumatic tires
- * Three finishing cut blades
- * Side discharge fabricated mower deck
- * Cutting Height 1.5" – 5.5" Manual 3 point full floating deck
- * Includes front mount anti-scalping rollers
- * 2.5 US gallon fuel capacity
- * Clevis/pin type hitch
- * 12V electric start
- * Manual PTO Clutch
- * 12V battery not included

MODEL	DESCRIPTION	WEIGHT	LIST PRICE
FC14560BS	60", 14.5 HP B&S engine Electric start	353 lbs.	\$2899

FINISHING MOWERS

Engine Driven



Gas powered mowers for lawn tractors and ATV's. This three spindle finishing mower comes complete with:

- * 11.5 HP Briggs & Stratton I/C engine with centrifugal clutch
- * Rear discharge
- * Spindle shafts greased from the top for easy service
- * Two front swivel tires and two rear non-swivel tires
- * Cutting height: 1" to 4"
- * Cat. 1 ball hitch
- * Semi pneumatic tires
- * 10 gauge reinforced mower deck
- * Heavy duty reinforced belt (BX)
- * Heavy duty, one piece, balanced steel pulleys
- * Safety kill switch
- * High blade tip speed

MODEL	CUTTING WIDTH	BLADE TIP SPEED (FT/MIN)	WEIGHT	LIST PRICE
C30CE5H	60"	14,173	388 lbs.	\$3199

FINISHING MOWERS

CHALLENGER III

3 PT. REAR DISCHARGE



The CHALLENGER III finishing mower manufactured by Howse Implement offers high performance features at a very affordable price; such as high blade tip speed, for easy cutting, and rear discharge to avoid windrowing & clumping of wet grass. Two models available, depending on your cutting requirements. For tractors 20 - 50 HP with Cat I 3 Pt. hitch and 540 RPM PTO.

- * Heavy duty 7 ga. (3/16" thick) mower deck
- * Rear discharge with safety chains
- * 13 x 6.5 4 ply (12" dia. x 5" wide) pneumatic flotation tires
- * Rear wheels offset to minimize turf compaction, scalping, & improve turning without tearing sod.
- * Flotation style Cat. I, 3 Pt. hitch to allow mower to follow contour of ground
- * 3 blade 1-1/4" spindle shafts with ball bearings
- * Category 4 PTO driveshaft
- * Powder coat paint for a better looking, longer lasting finish
- * Cutting height adjustment 1-1/2" up to 4-1/2"

MODEL	CUTTING WIDTH	BLADE TIP SPEED (FT/MIN)	WEIGHT	LIST PRICE
C360	60" / 5'	21,817	638 lbs.	\$1965
C372	72" / 6'	26,180	668 lbs.	\$2099

FINISHING MOWERS

C30 Series

Rear Discharge



Optional front anti-scalping roller

For tractors 16 to 30 HP, 540 RPM, Category 1, 3 Pt. hitch. Rear discharge, three spindle grooming mower.

- * Highly engineered & rugged gearbox with cooling fins
- * Front and rear tractor mounting
- * Four swivel 9" x 3.5" (4 ply with tubes) pneumatic tires
- * Floating 3 Pt. linkage, Cat. 1
- * 11 gauge reinforced mower deck
- * 1" to 4" cutting height
- * Spindle shafts greased from the top for easy service
- * Heavy duty reinforced belt (BX)
- * Heavy duty, one piece, balanced steel pulleys
- * High blade tip speed
- * Precise blade overlap

MODEL	CUTTING WIDTH	BLADE TIP SPEED (FT/MIN)	WEIGHT	LIST PRICE
C30RD5A	60"	14,763	364 lbs.	\$2599
C30RD6A	72"	14,566	429 lbs.	\$2825

OPTIONS:

MODEL	DESCRIPTION	LIST PRICE
001-600	Front antiscalping roller	\$120
005-600	Mulching kit for model C30RD5	\$365
006-600	Mulching kit for model C30RD6	\$389

FINISHING MOWERS

C50 Series

Rear Discharge

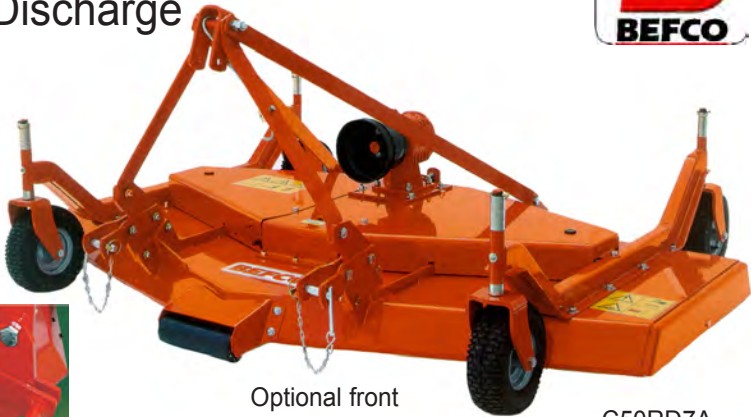

Optional front anti-scalping roller

C50RD7A Shown



Floating Linkage on 5' & 6'

Ideal for tractors from 20 to 50 HP. Category 1, 3 Pt. hitch, 540 RPM. These 3 spindle **BEFCO** rear discharge mowers come complete with:

- * 1" to 5" cutting height
- * Highly engineered & rugged gear box with cooling fins
- * Heavy duty shielded PTO shaft (1-3/8" ASAE Cat. 3)
- * Four height control bearingwheels
- * Floating 3 Pt. linkage, Cat. 1
- * Spindle shafts greased from the top for easy service
- * Heavy duty, one piece, balanced steel pulleys
- * Two heavy duty reinforced belts (SPBX)
- * High blade tip speed
- * Pneumatic tires 11" x 4" (4 ply with tube)
- * 8 gauge reinforced mower deck
- * Four castor wheels
- * C50RD5 & C50RD6 mowers include standard CAT. I lower lift pins
- * C50RD7 mower includes CAT. I clevis type lower lift pins

MODEL	CUTTING WIDTH	BLADE TIP SPEED (FT/MIN)	WEIGHT	LIST PRICE
C50RD5A	60"	16,929	534 lbs.	\$3399
C50RD6A	72"	16,732	584 lbs.	\$3599
C50RD7A	84"	16,338	674 lbs.	\$4199

OPTIONS:

MODEL	DESCRIPTION	LIST PRICE
009-9915	Front anti-scalping roller for 5' and 6' mowers, standard on 7' mower	\$139
009-9815	Professional front anti-scalping roller	\$190
005-700	Mulching kit for model C50RD5	\$375
006-700	Mulching kit for model C50RD6	\$429
007-700	Mulching kit for model C50RD7	\$499

FINISHING MOWERS

C70 Series

Rear Discharge



For tractors from 30 to 70 HP, Category 1, 3 Pt. hitch, 540 RPM. These 3 spindle **BEFCO** rear discharge mowers come complete with:

- * Highly engineered & rugged gearbox with cooling fins
- * Cutting height: 1.3" to 5.3"
- * Front and rear tractor mounting
- * Four heavy duty bearing wheels
- * Floating 3 Pt. linkage, Cat. 1
- * Two heavy duty reinforced belts (CX)
- * Heavy duty shielded PTO shaft (1-3/8" ASAE Cat. 4)
- * Six free swinging kick back blades
- * Spindle shafts greased from the top for easy service
- * Heavy duty, one piece, balanced steel pulleys
- * High blade tip speed
- * Pneumatic tires 13" x 6.5" 4 ply with tubes
- * Front anti-scalping roller
- * 8 gauge reinforced mower deck
- * Optional hard rubber, semi-pneumatic tires available

MODEL	CUTTING WIDTH	BLADE TIP SPEED (FT/MIN)	WEIGHT	LIST PRICE
C70090A	90"	13,976	1137 lbs.	\$6669
C70110A	110"	14,960	1290 lbs.	\$7849

FLEX MOWERS

3 Pt. Hitch



- * HP Requirements: 40-80, 540 RPM
- * 1" to 4" cutting height
- * Available in rear 3 Pt. or front 3 Pt. hitch mounting, specify at time of order
- * Single action hydraulic folding wings
- * Cat. 1, 3 Pt. hitch
- * Heavy duty reinforced belts (BX)
- * Driveline with slip clutch (1-3/8" ASAE Cat. 6)
- * Three completely independent free floating mower decks
- * Transport width 7'10" max.
- * Transport safety locks
- * Unique double pivot floating linkage
- * Front anti-scalping roller standard
- * 4 pneumatic tires with bearings per mower deck
- * 9" x 3.5" pneumatic tires (4 ply with tubes)
- * Includes detachable wheeled transport frame

MODEL	CUTTING WIDTH	UNIT MAKEUP	WEIGHT	LIST PRICE
112EZFA	12'	(2) EZ4 & (1) EZ6	1870 lbs.	\$15,499

OPTIONS:

MODELS	DESCRIPTION	LIST PRICE
009-9592	Mulching kit for model 112EZF (3 units)	\$1049
009-9593	Hydraulic unlocking system	\$599

FLEX MOWERS

Pull Type Cyclone Flex



For technical specifications on individual mower decks
see page 21 (C50 Mowers)

- * HP Requirements: 25-60, 540 RPM
- * Heavy duty transport frame
- * Cutting height: 1" to 5"
- * Pull type mower with high flotation transport tires (20.5" x 8"x10")
- * Single action hydraulic folding wing system for easy transport and storage
- * Transport width 7' 10" max.
- * CV driveline with slip clutch (1-3/8" ASAE Cat. 6)
- * Deck overlap adjustment 6"
- * Three front anti-scalping rollers standard
- * Safety chain shield standard
- * Remote safety locks for transporting
- * Each mower deck has four 11" x 4" (4 ply pneumatic tires & tubes)
- * Optional hard rubber, semi-pneumatic tire for mower decks available. Specify at time of order

MODEL	CUTTING WIDTH	UNIT MAKE UP	WEIGHT	LIST PRICE
312FLXA	12'	(2) FX4 & (1) FX5	2694 lbs.	\$18,799
315FLXA	15'	(2) FX5 & (1) FX6	2826 lbs.	\$20,549
317FLXA	17'	(3) FX6	2947 lbs.	\$21,339

OPTIONS:

MODEL	DESCRIPTION	LIST PRICE
009-9556	Mulching kit for model 312-FLX (3 units)	\$1110
009-9557	Mulching kit for model 315-FLX (3 units)	\$1219
009-9558	Mulching kit for model 317-FLX (3 units)	\$1325
009-9552	Hydraulic unlocking system	\$599
009-9597	Floating hitch	\$275

FLEX MOWERS

Super-Flex Pull Type



For technical specifications on individual mower decks
see page 21 (C50 Mowers)

- * HP Requirements: 35-80, 540 RPM
- * Extra heavy duty transport frame
- * 1" to 5" cutting height
- * Pull type mower with high flotation transport tires (23" x 10.5" x 12")
- * Single action hydraulic folding wing system for easy transport and storage
- * Three front anti-scalping rollers standard
- * CV driveline with slip clutch (1-3/8" ASAE Cat. 6)
- * Deck overlap adjustment 6"
- * Safety chain shield standard
- * Remote safety locks for transporting
- * Each mower deck has four 13" x 6.5" (4 ply air tires with tubes)

MODEL	CUTTING WIDTH	UNIT MAKEUP	WEIGHT	LIST PRICE
412SFLA	12'	(2) SF4 & (1) SF5	3090 lbs.	\$22,099
415SFLA	15'	(2) SF5 & (1) SF6	3267 lbs.	\$23,239
417SFLA	17'	(3) SF6	3438 lbs.	\$25,199
420SFLA	20'	(3) SF7	3747 lbs.	\$28,369

OPTIONS:

MODEL	DESCRIPTION	LIST PRICE
009-9556	Mulching kit for model 412-SFL (3 units)	\$1110
009-9557	Mulching kit for model 415-SFL (3 units)	\$1219
009-9558	Mulching kit for model 417-SFL (3 units)	\$1325
009-9559	Mulching kit for model 420-SFL (3 units)	\$1549
009-9552	Hydraulic unlocking system	\$599
009-9597	Floating hitch	\$275

FLAIL MOWERS

H40 Series, Hurricane



For tractors from 15 to 40 HP, Category 1, 3 Pt. hitch, 540 RPM. Flail mowers come complete with:

- * 1" to 5" cutting height
- * Two heavy duty reinforced notched belts (SPBX)
- * Highly engineered & rugged gearbox with cooling fins
- * High blade tip speed
- * Adjustable cutting height roller
- * Perfectly balanced rotor
- * Two pc. regular cut knives - Optional
- * Two pc. fine cut knives - Standard
- * Clockwise rotation is standard
- * Offset from center: 3" on H40-048
8.5" on H40-060
6.5" on H40-072
- * Front rubber safety shielding
- * Optional hammer type blades available

MODEL	CUTTING WIDTH	STANDARD # BLADES	OFFSET	WEIGHT	LIST PRICE
H40-048	48"	48	3"	418 lbs.	\$3279
H40-060	60"	64	8.5"	456 lbs.	\$3499
H40-072	72"	76	6.5"	528 lbs.	\$3869

OPTIONS:

MODEL	DESCRIPTION	LIST PRICE
009-9507	Side skid shoes (pair)	\$110
009-9200	*Hammer type blades for model H40-048	\$265
009-9201	*Hammer type blades for model H40-060	\$350
009-9202	*Hammer type blades for model H40-072	\$420

*Specify at time of order

FLAIL MOWERS

H70 Series, Hurricane



For tractors from 30 to 70 HP, Category 1, 3 Pt. hitch, 540 RPM. Flail mowers come complete with:

- * 3/4" to 6" cutting height
- * Front & rear tractor mounting
- * Adjustable cutting height roller with scraper
- * High blade tip speed
- * Heavy duty shielded PTO shaft with over running clutch (1-3/8" ASAE Cat. 4).
- * Highly engineered & rugged gearbox
- * Electronically balanced rotor
- * Two heavy duty reinforced notched belts (CX)
- * Semi-automatic belt tensioner
- * Floating top link
- * Sealed rotor bearings
- * Fine cut (2 Pc) knives-standard
- * Regular cut (2 pc reversible Y) knives - Optional
- * Forward rotor rotation is standard
- * Reverse rotor rotation is optional (Extra)
- * Rotor RPM: 2080
- * Blade tip speed (ft/min): 8464
- * Optional hammer type blades available

MODEL	CUTTING WIDTH	OVERALL WIDTH	# BLADES	WEIGHT	LIST PRICE
H70-060	60"	71"	64	869 lbs.	\$6699
H70-072	72"	85"	80	955 lbs.	\$7159
H70-088	88"	99"	96	1078 lbs.	\$7369

OPTIONS:

MODEL	DESCRIPTION	LIST PRICE
009-9691	Gauge wheels with laminated tires (pair)	\$1025
009-9201	*Hammer type blades for model H70-060	\$350
009-9203	*Hammer type blades for model H70-072	\$445
009-9204	*Hammer type blades for model H70-088	\$529

*Specify at time of order

FLAIL MOWERS

H80 Series

Hurricane Commercial

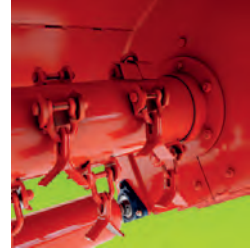

Ideal for tractors from 40 to 80 HP, Category 1 and 2, 3 Pt. hitch, 540 RPM. Flail mowers come complete with:

- * 3/4" to 6" cutting height
- * Frame thickness: 8 gauge
- * Side plates thickness: 5/16"
- * Rotor diameter: 6"
- * Rotor wall thickness: 5/16" (72") & 3/8" (88" and 100")
- * Regular cut (2 pc. reversible Y) blades - standard
- * Fine cut (2 pc.) blades - optional
- * High blade tip speed
- * Adjustable cutting height roller with scraper
- * Highly engineered gearbox
- * Front & rear tractor mounting
- * Electronically balanced rotor
- * Heavy duty, one piece, balanced steel pulleys
- * Two heavy duty reinforced notched belts (CX)
- * 3 Pt. linkage, Cat. 1 and 2
- * Floating top link
- * Forward rotor rotation is standard
- * Reverse rotor rotation is optional (Extra)
- * Replaceable skid shoes
- * Semi-automatic belt tensioner
- * Sealed 2" rotor bearings
- * Driveline with over-running clutch (1-3/8" ASAE Cat. 6)
- * Rotor RPM: 1873
- * Blade tip speed (ft/min): 8268
- * Optional hammer type blades available

MODEL	CUTTING WIDTH	OVERALL WIDTH	# BLADES	WEIGHT	LIST PRICE
H80-072	72"	85"	80	1153 lbs.	\$9029
H80-088	88"	99"	96	1296 lbs.	\$9949
H80-100	100"	110"	104	1486 lbs.	\$10,999

OPTIONS:

MODEL	DESCRIPTION	LIST PRICE
009-9701	Gauge wheels with laminated tires (pair)	\$1215
009-9203	*Hammer type blades for model H80-072	\$445
009-9204	*Hammer type blades for model H80-088	\$529
009-9205	*Hammer type blades for model H80-100	\$575

*Specify at time of order

FLAIL SHREDDER

Destroyer Series



New from BEFCO a heavy duty Flail shredder, with hydraulic side shift. Available in three sizes 60", 72", and 88". Comes standard with Cat. I & II rear mounted 3 Pt. hitch. Heavy duty hammer type blades that can shred material up to 2" thickness. Horse power recommended 40- 90.

- * Cat. I & II Rear Mount 3 Pt. Hitch
- * 540 RPM PTO with Overrunning Clutch is standard
- * 4 Belt Driven Transmission, with Manual Belt Tensioner
- * Hydraulic Side Shift (Offset) 12" on 60" model & 16" on 72" & 88" models
- * Heavy Duty Hammer Type blades
- * Rotor Diameter 133mm(5-1/4"), 8mm(1/4") thick tube
- * Height adjustment via rear roller, with scraper
- * Rear Roller Diameter 168mm(6-1/2"), 4.5mm(3/16") thick tube

MODEL	D90-060	D90-072	D90-088
WORKING WIDTH	60"	72"	88"
OVERALL WIDTH	69"	81"	96"
WEIGHT	1257 lbs.	1345 lbs.	1491 lbs.
# OF HAMMERS	16	20	24
HYD SIDE SHIFT	12"	16"	16"
CUTTING CAPACITY	2"	2"	2"
PRICE	\$8549	\$8999	\$9539

OPTIONS:

MODEL	DESCRIPTION	LIST PRICE
009-9968	*Dual PTO gear box and front mount 3 Pt. hitch (Factory Installed)	\$365
009-9969	Skid shoes (pair)	\$239

*Specify at time of order

H&S

Innovation + Technology + The Market Leader = H&S Forage Boxes!



XTRACAP Forage Boxes Feature:

- * More Cross Members
- * New Color Scheme
- * More Capacity
- * More Uprights
- * More Height

Buy the BEST
BUY **H&S**



"SUPER DUTY" Forage Boxes are available
w/ Electric-Over-Hydraulic Cab Controls!

H&S
Wide
Body
"The Only
Box with
Patented
Center
Drive"



ROTARY TILLER

Engine Driven - Pull Type



The Agri-Fab Multi-Fit tow behind rotary tiller comes with a 6.5 HP B&S Intek engine and has a 36" tilling width with conveniently located controls. Quickly prepare the perfect planting bed with minimal effort. Can be used with any ATV or garden tractor above 12 HP.

- * 205cc B&S Intek Engine
- * Recoil start
- * 36" Tilling width
- * Forward rotating tines
- * Six double edge 11" diameter heavy duty tines
- * Tilling depth adjustable from 1-1/2" to 5-1/2"

MODEL	DESCRIPTION	WEIGHT	LIST PRICE
450308	Pull type - 36"	229 lbs.	\$1699

ROTARY TILLERS

Manual Side-Shift



The **ROTOMECH** tiller is a rugged machine with an extremely simple and functional side shift at no additional charge. Ideal for tractors ranging from 20 to 40 HP. Tillers come complete with:

- * Highly engineered and rugged gearbox
- * Four knives per flange
- * Solid rotor shaft
- * Heavy duty tiller blades
- * Shielded shear pin PTO
- * Cat I 3 Pt. hitch
- * Reinforced lateral 80 ASA chain drive transmission in oil bath
- * Adjustable skids for depth control
- * Exchangeable sprockets for 2 rotor speeds, 231/375 RPM
- * Working Depth up to 7 1/4"

MODEL	WORKING WIDTH	OFFSET	# FLANGES	# KNIVES	WEIGHT	LIST PRICE
142-231	42"	10"	5	20	373 lbs.	\$2299
150-231	50"	14"	6	24	407 lbs.	\$2369
158-231	58"	18"	7	28	452 lbs.	\$2499
166-231	66"	22"	8	32	492 lbs.	\$2699

ROTARY TILLERS

T30 Series

Manual Side-Shift



For tractors from 18 to 30 HP. Category 1, 3 Pt. hitch, 540 RPM PTO. T30 series tillers come complete with:

- * HP Requirements: 16-30, 540 RPM
- * Highly engineered and rugged gearbox with cooling fins
- * Four blades per flange
- * High carbon solid steel round rotor shaft allows for a deeper working depth
- * Heavy duty full size blades
- * Heavy duty shielded PTO shaft with shear pin coupling (1-3/8" ASAE Cat. 2)
- * # 60 chain drive
- * Adjustable side skirts for working depth control

	WORKING					LIST
MODEL	WIDTH	OFFSET	# FLANGES	# BLADES	WEIGHT	PRICE
T30-134	34"	6"	4	16	297 lbs.	\$2279
T30-142	42"	10"	5	20	341 lbs.	\$2359
T30-150	50"	14"	6	24	374 lbs.	\$2489

OPTIONS:

MODEL	DESCRIPTION	LIST PRICE
009-9538	Cat. 0, 3 Pt hitch (Specify at time of ORDER)	\$175

Specify at time of order

Weights indicated are base machine weight, not shipping weight

ROTARY TILLERS

T40 Series

Manual Side-Shift



For tractors up to 40 HP. Category 1, 3 Pt. hitch, 540 RPM PTO. T40 series tillers come complete with:

- * Highly engineered and rugged gearbox
- * Four blades per flange
- * Solid steel rotor shaft
- * Adjustable side skids for working depth control
- * Wear protection on chain case
- * Heavy duty full size blades
- * Heavy duty shielded PTO shaft with slip clutch safety (1-3/8" ASAE Cat. 3)
- * # 80 chain drive with exchangeable sprockets for 2 rotor speeds, 231/375 RPM

	WORKING					LIST
MODEL	WIDTH	OFFSET	# FLANGES	# BLADES	WEIGHT	PRICE
T40-242	42"	10"	5	20	373 lbs.	\$2899
T40-250	50"	14"	6	24	417 lbs.	\$2999
T40-258	58"	18"	7	28	461 lbs.	\$3139
T40-266	66"	22"	8	32	530 lbs.	\$3449

ROTARY TILLERS

T50 Series

Manual Side-Shift



For tractors up to 50 HP. Category 1, 3 Pt. hitch, 540 RPM PTO. T50 series tillers come complete with:

- * HP Requirements: 25-50, 540 RPM
- * Highly engineered and rugged gearbox
- * Six blades per flange for greater stability & finer soil pulverization
- * Solid steel rotor shaft
- * Heavy duty shielded PTO with shaft with slip clutch safety (1-3/8" ASAE Cat. 4)
- * Heavy duty full size tiller blades
- * Wear protection on chain case
- * Adjustable side skirts for working depth control
- * Lateral #100 Roller Chain drive transmission in oil bath
- * Exchangeable sprockets for two rotor speeds 226/383 RPM
- * Max. working depth 8-3/8"

MODEL	WORKING			# BLADES	WEIGHT	LIST PRICE
	WIDTH	OFFSET	# FLANGES			
T50-350	50"	14"	6	36	481 lbs.	\$3649
T50-358	58"	18"	7	42	528 lbs.	\$3769
T50-366	66"	22"	8	48	575 lbs.	\$3825

ROTARY TILLERS

T60 Series

Manual Side-Shift



For tractors up to 60 HP. Category 1, 3 Pt. hitch, 540 RPM PTO. T60 series tillers come complete with:

- * HP Requirements: 30-60, 540 RPM
- * Highly engineered and rugged gearbox
- * Six blades per flange for greater stability & finer soil pulverization
- * Solid steel rotor shaft
- * Heavy duty full size tiller blades
- * Wear protection on chain case
- * Adjustable side skirts for working depth control
- * # 100 chain drive in oil bath
- * Heavy duty shielded PTO shaft with slip clutch safety (1-3/8" ASAE Cat.6)
- * Max. working depth 8-3/8"

	WORKING					LIST
MODEL	WIDTH	OFFSET	# FLANGES	# BLADES	WEIGHT	PRICE
T60-366	66"	22"	8	48	740 lbs.	\$4949
T60-374	74"	26"	9	54	798 lbs.	\$5149

ROTARY TILLERS

T70 Series



For tractors up to 70 HP. Category 1, 3 Pt. hitch, 540 RPM PTO. T70 series tillers come complete with:

- * HP Requirements: 30-70, 540 RPM
- * Heavy duty reinforced frame
- * Six blades per flange for greater stability & finer soil pulverization
- * Max working depth 8-3/4"
- * Wear protection on chain case
- * Heavy duty shielded PTO shaft with slip clutch safety (1-3/8" ASAE Cat.6)
- * Adjustable side skids for working depth control
- * Flanged rotor shaft for easy removal & service
- * Solid steel rotor shaft
- * Heavy duty gearbox
- * # 100 chain drive transmission in oil bath

MODEL	WORKING WIDTH	OFFSET	# FLANGES	# BLADES	WEIGHT	LIST PRICE
T70-382	82"	22"	10	60	879 lbs.	\$5399

SOIL-PULVERIZERS



- * 3/8" steel spikes fully welded in a timed scroll pattern
- * 10" frame beam (Standard)
- * 12" frame beam (Heavy Duty)
- * Two rows heavy duty reversible heat treated scarifier shanks
- * 5-9/16" dia. spiked roller tube (Standard)
- * 6-5/8" dia. spiked roller tube (Heavy Duty)
- * Complete with two 160 lbs. compression roller springs
- * Optional 2nd spiked roller available with 2-80 lb. compression
- * Reversible heat treated 1/2" x 2" shanks
- * 3 Pt. linkage, Cat. 1
- * Self aligning 1" bearing on roller
- * Formed plate "A" frame
- * Shank spacing 2-13/16"

STANDARD

MODEL	WORKING WIDTH	WEIGHT	# SHANKS	# ROLLER SPIKES	LIST PRICE
BPL048	48"	496 lbs.	17	70	\$1889
BPL060	60"	652 lbs.	21	88	\$2019
BPL072	72"	679 lbs.	25	106	\$2225

HEAVY DUTY

MODEL	WORKING WIDTH	WEIGHT	# SHANKS	# ROLLER SPIKES	LIST PRICE
BPL284	84"	875 lbs.	29	124	\$3019

OPTIONS:

Add-on double roller includes bracket & bearings

MODEL	DESCRIPTION	LIST PRICE
009-9887	48" x 5" dia. for BPL048	\$535
009-9636	60" x 5" dia. for BPL060	\$619
009-9637	72" x 5" dia. for BPL072	\$755
009-9647	84" x 5-9/16" dia. for BLP284	\$949

CORE AERATORS

Heavy Duty



Shown with optional Steel Weight Tanks

- * Spoon spacing 6-1/2"
- * Working depth 4-1/2"
- * Special high tensile steel shafts on the rotors
- * Two bronze bushings per rotor
- * 3/16" formed steel support panels
- * All panels support rotors from all sides
- * 1-1/4" rotor support shaft
- * 3 Pt. linkage Cat. 1 and 2
- * Cat. 1 and 2 quick hitch adaptable
- * Eight spoons per hub
- * All flanges are welded to rotors
- * Rotor flange thickness 3/16"
- * Three support stands
- * 3/4" hardened steel spoons
- * Front or rear tractor mounting

MODEL	WORKING OVERALL		WEIGHT	# SPOONS	ADDITIONAL	
	WIDTH	WIDTH			WEIGHT	LIST PRICE
BCA260	60"	65"	444 lbs.	80	19" x 21"	\$2989
BCA272	72"	78"	549 lbs.	96	25" x 21"	\$3299

OPTIONS:

MODEL	DESCRIPTION	LIST PRICE
009-9734	Steel weight tank (model BCA260) 2 Required	\$355
009-9735	Steel weight tank (model BCA272) 2 Required	\$385

Weights indicated are base machine weight, not shipping weight

SEEDER/OVERSEEDER SEED-RITE



The BEFCO Seed-Rite is a primary full width seeder / overseeder. 74" working width, with a ground drive system for seed hopper. Steel seed box comes with a steel shaft agitator with ten high precision metering seed cups, with a wide range of calibration settings per acre. Two nylon/fiberglass corrugated rollers 9-1/2" in diameter the working width of seeder compact seed into soil. Unit can also be used as an overseeder for seeding existing lawns, parks etc.

- * **Cat. I, 3 Pt. Hitch (quick hitch compatible)**
- * **Parking stands**
- * **74" seeding width**
- * **80" overall width**
- * **Heavy duty frame**
- * **Heavy duty seed box lid with seed splash guard**
- * **Seed box capacity 7 cu.ft.(5-1/2 Bu.)**
- * **Seed box agitator**
- * **10 high precision metering seed cups**
- * **Wind guarded seed drop**
- * **Two 9-1/2" diameter nylon/fiberglass corrugated rollers**
- * **Greaseable roller bearings**
- * **Two spring tine track removers**

MODEL	DESCRIPTION	WEIGHT (LBS.)	LIST PRICE
SRT074	74" Seed-Rite Seeder/Overseeder	990 lbs.	\$6199

OPTIONS:

MODEL	DESCRIPTION	LIST PRICE
009-9930	Rear Expanded Roller Frame with Adjustable Tickler Tines for Seed Covering & De-thatching	\$619

AERATOR / OVERSEEDER

Green-Rite



For tractors from 25 to 70 HP. Category 1, 3 Pt. hitch. 540 RPM PTO. **BEFCO** Green-Rite Overseeders/Primary seeders come complete with:

- * **HP Requirements: 25-70, 540 RPM**
- * **Series T40 rotary tiller base machine on 50", 58", 66" and T70 on 82"**
- * **Special 2.8" flange spacing on rotor for aerating with 3 knives per flange on GRT250, GRT258 & GRT266**
- * **4 knives per flange on GRT288**
- * **Straight aerator knives**
- * **Seed covering/dethatching adjustable tickler tines**
- * **Seed hopper with metering cups**
- * **Ground drive system for seed hoppers**
- * **Corrugated depth control roller made with low weight nylon/fiberglass roller rings**
- * **Heavy duty shielded PTO shaft with slip clutch safety**

MODEL	WORKING WIDTH	HOPPER CAP. CU. FT.	# FLANGES	# BLADES	WEIGHT	LIST PRICE
GRT250	50"	4.60	15	43	910 lbs.	\$9279
GRT258	58"	5.30	18	52	998 lbs.	\$9549
GRT266	66"	6	21	61	1170 lbs.	\$10,699
GRT282	82"	7.6	26	104	1500 lbs.	\$13,789

NOTE: Units may utilize gauge wheels or a gauge roller for blade depth control, but not both.

OPTIONS:

MODEL	DESCRIPTION	LIST PRICE
009-9875	Gauge wheels for all models	\$429
009-9648	Front roller for GRT-250	\$679
009-9516	Front roller for GRT-258	\$719
009-9563	Front roller for GRT-266	\$799
009-9566	Front roller for GRT-282	\$839
009-9649	Tiller rotor for GRT-250	\$669
009-9517	Tiller rotor for GRT-258	\$759
009-9564	Tiller rotor for GRT-266	\$849
009-9567	Tiller rotor for GRT-282	\$1569
009-9650	Rear roller scraper for GRT-250	\$239
009-9539	Rear roller scraper for GRT-258	\$269
009-9565	Rear roller scraper for GRT-266	\$379
009-9568	Rear roller scraper for GRT-282	\$429

ATV ENGINE DRIVEN SNOWBLOWER

Agri-Fab®
Lawn Care Made Easy™



The Agri-Fab ATV dual stage snowblower has a 50" clearing width and comes with an 11HP Tecumseh Snow King engine that is engineered to start on the coldest of days. The large recoil starter handle allows for easy pulling with mitts or gloves on. The snowblower has a serrated auger with 5/16" shear pins and a large 12" diameter impeller, clutch engagement, directional controls and a conveniently located kill switch adjacent to the ATV's handlebars. Also includes a 12 volt electric lift and castor type transport wheels which take the weight of the snowblower off the front of ATV making turning a breeze.

- * **50" clearing width**
- * **21" Intake height**
- * **11HP Tecumseh SNOW KING engine**
- * **Recoil start**
- * **1 Gallon fuel tank**
- * **Rugged 5" poly discharge chute, adjustable up and down and rotates side to side 180°**
- * **Includes mounting brackets to fit most ATV's**

MODEL	DESCRIPTION	WEIGHT (LBS.)	LIST PRICE
450418	2 Stage 50", 11HP Snowblower	380 lbs.	\$4109

OPTIONS:

MODEL	DESCRIPTION	LIST PRICE
450391	Universal ATV Snow Cab	\$129

SNOW PLOW GARDEN TRACTOR & ATV

Agri-Fab
Lawn Care Made Easy™



The patented NORDIC PLOW is a front mount blade made of high impact injected molded plastic and utilizes a “round” lower edge. This makes the NORDIC PLOW available for year round use. It glides easily over grass and paver bricks, so you can push dirt, sand or mulch as well as snow. The NORDIC PLOW adjusts/angles left or right with a release pin. It can also be raised or lowered manually, due to it’s lightweight design with a hand strap. On ATV’s you can utilize your front mounted winch for raising and lowering. The NORDIC PLOW includes universal fit mounting brackets to fit most traditional lawn & garden tractors (48” wide blade) and ATV’s (60” wide blade)

- * **Manufactured of high impact injected molded plastic**
- * **Light weight**
- * **48" wide blade for lawn & garden tractor includes universal lawn & garden tractor mounting brackets**
- * **60" wide blade for ATV's includes universal ATV mounting brackets**
- * **Angles left or right**
- * **Raises & lowers by hand strap**

MODEL	DESCRIPTION	WEIGHT	LIST PRICE
450498	NORDIC 48" PLOW for standard lawn & garden	62 lbs.	\$539
450499	NORDIC 60" PLOW for standard ATV's	82 lbs.	\$650

REAR SCRAPER BLADES 3 Pt. SXGB Series



Howse Implement rear scraper blades are Cat. I 3 Pt. hitch and are available in 4', 5', 6' and 7' working widths. Rated for tractors up to 45 HP, they have a replaceable 6" cutting edge and have a quick and easy left or right angle ability in forward or reverse position.

- * Cat. 1, 3 Pt. hitch
- * Moldboard 14" high x 3/16" thickness
- * Reversible 1/2" x 6" cutting edge
- * Welded A-Frames
- * Full swivel 360° swivel with approximately 22° and 45° angle forward and reverse

MODEL	WIDTH	WEIGHT	LIST PRICE
SXGB4	4'	174 lbs.	\$349
SXGB5	5'	189 lbs.	\$389
SXGB6	6'	208 lbs.	\$429
SXGB7	7'	232 lbs.	\$499

REAR SCRAPER BLADES 3 Pt. MEDIUM DUTY



Howse medium duty scraper blades are category 1 3 Pt. hitch, and are available in 5', 6' & 7' working widths, rated for tractors up to 65 HP. They are offsetable, the heavy duty reinforced moldboard tilts right or left and fully swivels 360 degrees with a 22 degree and 45 degree angle forward and reverse.

- * **Cat. 1, 3 Pt. Hitch**
- * **Heavy duty 4" x 4" tubing main frame**
- * **Welded 3 Pt. A-Frame**
- * **Heavy Duty Reinforced Moldboard 14" high x 1/4"**
- * **Reversible 1/2" x 6" cutting edge**
- * **Offsetable 22° and 45°**
- * **Moldboard tilts left or right approximately 22 degrees**
- * **Full 360° swivel with 22° and 45° angle forward and reverse positions**
- * **Rated for 65 HP tractors.**

MODEL	WIDTH	WEIGHT	LIST PRICE
SXOSHGB5	5'	312 lbs.	\$599
SXOSHGB6	6'	344 lbs.	\$669
SXOSHGB7	7'	376 lbs.	\$759

REAR SCRAPER BLADES

Heavy Duty



These heavy duty rear scraper blades are designed to give you the quality, dependable performance that you require. They come with Category 1 and 2, 3 Pt. hitch for 35 to 85 HP. These units come equipped with quick tilt, angle and offset manual adjustments. A parking stand is standard.

- * **HP Requirements: 35-85**
- * **Tilt adjustments: 15-16° right or left**
- * **Offset adjustments: 15-30° right or left**
- * **Moldboard thickness: 1/4"**
- * **Moldboard height: 17"**
- * **Reversible 1/2" x 6" cutting edge**
- * **Angle adjustment 15° - 16° - 45° forward or reverse**
- * **Cat. 1 and 2, 3 Pt. hitch**

MODEL	WIDTH	WEIGHT	LIST PRICE
GB484	7'	576 lbs.	\$1549
GB496	8'	652 lbs.	\$1599

SCRAPER BLADE HD HYDRAULIC



This 8 foot heavy duty rear scraper blade comes standard with one hydraulic cylinder for angling. It is built heavy to handle your roughest conditions. The blade can angle hydraulically, and offset and tilt manually.

- * Cat II 3 Pt hitch
- * 90 HP rated
- * 19" high moldboard
- * 1/4" thick moldboard
- * 6" reversible cutting
- * Comes with hydraulic hoses & coupler plugs
- * Angles Hydraulically
- * Offsets & tilts manually
- * Optional hydraulic tilt kit available

MODEL	DESCRIPTION	WEIGHT	LIST PRICE
GB496H	8'96" HD Scraper Blade	904 lbs.	\$2049

OPTIONS:

MODEL	DESCRIPTION	WEIGHT	LIST PRICE
GB009HC	Hydraulic Tilt Kit	28 lbs.	\$549
	Comes with Hydraulic cylinder, hoses & coupler plug		

SNOW BLADES SKID STEER & FRONT TRACTOR LOADERS

5' & 6' Working Widths



- * Recommended HP 25 - 45
- * Maximum operating weight 4,500 lbs.
- * 2 trip springs for controlled break over in snow
- * Blade locks for light grading of loose dirt or gravel
- * 3/8" x 6" reversible hardened steel cutting edge
- * 6" x 1/2" thick rotating height adjustable skid shoes
- * 21" high moldboard
- * Manual angle adjustment is standard
- * Optional hydraulic angle adjustment kit available

MODEL	DESCRIPTION	WEIGHT	PRICE
SBS2160	5 ft. snow blade for compact tractors with loaders that utilize the "Universal" skid steer quick attach system	325 lbs.	\$2149
SBFL2160	5 ft. snow blade for compact tractors with loaders requiring optional interfacing quick attach brackets. Order extra	335 lbs.	\$2099
SBS2172	6 ft. snow blade for compact tractors with loaders that utilize the "Universal" skid steer quick attach system	353 lbs.	\$2229
SBFL2172	6ft. Snow blade for compact tractors with loaders requiring optional interfacing quick attach brackets. Order extra	360 lbs.	\$2129

OPTIONS:

MODEL	DESCRIPTION	WEIGHT	LIST PRICE
360170	Optional hydraulic angle adjustment kit includes cylinders, fittings and hoses between cylinders. Does NOT INCLUDE hydraulic hoses or quick couplers to tractor remotes	40 lbs.	\$459
360065	Optional crossover relief valve protects blade from damage	7 lbs.	\$299
360220	Optional top deflector for 5ft blade		\$139
360223	Optional top deflector for 6ft blade		\$169
360235	Optional sight indicators		\$49

SNOW BLADES SKID STEER & FRONT TRACTOR LOADERS 7.5' & 9' Working Widths



- * Recommended HP 30 - 80
- * 2 trip springs for controlled break over in snow
- * Blade locks for light grading of loose dirt or gravel
- * 3/8" x 6" reversible hardened steel cutting edge
- * 6" x 1/2" thick rotating height adjustable skid shoes
- * 27" high moldboard
- * 5 degree lateral oscillation
- * Manual angle adjustment is standard 7.5 ft model
- * Optional hydraulic angle kit available for 7.5 ft model
- * Hydraulic angle adjustment standard on 9 ft model

MODEL	DESCRIPTION	WEIGHT	PRICE
SBS2790A	7.5 ft. snow blade for tractors with loaders or skid steers that utilize the "Universal" skid steer quick attach system	646 lbs.	\$2939
SBFL2790A	7.5 ft. snow blade for tractors with loaders requiring optional interfacing quick attach brackets. Order extra	660 lbs.	\$2879
SBS27108A	9 ft. snow blade for tractors with loaders or skid steers that utilize the "Universal" skid steer quick attach system Includes 360065 crossover relief valve	735 lbs.	\$3999
SBFL27108A	9 ft. snow blade for tractors with loaders requiring optional interfacing quick attach brackets. Order extra Includes 360065 crossover relief valve	748 lbs.	\$4039

OPTIONS:

MODEL	DESCRIPTION	WEIGHT	LIST PRICE
360168	Optional hydraulic angle adjustment kit includes cylinders, fittings and hoses between cylinders. Does NOT INCLUDE hydraulic hoses or quick couplers to tractor remotes	40 lbs.	\$399
360065	Optional crossover relief valve protects blade from damage	7 lbs.	\$299
360227	Optional top deflector for 7.5 ft blade		\$185
360230	Optional top deflector for 9 ft blade		\$239
360235	Optional sight indicators		\$49

SNOW BLADES CLAMP-ON TO BUCKET



- * Available in 5' & 6' widths
- * 21" high moldboard
- * Uses chain & turnbuckle to fasten to material bucket
- * For tractor loaders & skid steers up to 35 HP

MODEL	DESCRIPTION	WEIGHT	PRICE
SBC2160	5' / 60" clamp-on snow blade	305 lbs.	\$1899
SBC2172	6' / 72" clamp-on snow blade	335 lbs.	\$1959

OPTIONS:

MODEL	DESCRIPTION	LIST PRICE
360220	Optional top deflector for 5ft blade	\$139
360223	Optional top deflector for 6ft blade	\$169



>> H&S RAKES... BEST IN CLASS!



> The **ACTION Rake** is the **ONLY** Rake on the market that features the unique "Kwik Pik" System for Immediate Clearance of Windrows when Raised!

> Available in 8, 10, & 12 wheel models, the CR & ACTION Rakes feature a **PROVEN Rake Arm Pivot Joint** for Flexibility!



Buy the **BEST**
BUY **H&S**



The most flexible rake on the market, the H&S 12, 14, & 16 wheel Hi-Capacity Rakes have the rake wheels positioned ahead of the arms, main frame beams and transport wheels, so there are no hang-up points when raking heavy crop.

BOX SCRAPERS

Standard Duty



The HOWSE Implement standard duty box scraper is available in 4 working widths. These box scrapers are quality built and are ideal for landscape, farm or estate use. They come with a 6" reversible cutting edge front and rear and adjustable spring steel scarifier shanks with replaceable points. These units are quick hitch compatible.

- * **Cat. I, 3 Pt. Hitch**
- * **Two 6" Reversible Cutting Edges, Front and Back**
- * **Adjustable Spring Steel Scarifier Shanks**
- * **With Replaceable Points**
- * **HP Rating 30 – 35 HP**
- * **Quick Hitch Compatible**

MODEL	WIDTH	# SHANKS	HP RATING	WEIGHT	LIST PRICE
BSXEB48	4' / 48"	4	30 HP	300 lbs.	\$599
BSXEB60	5' / 60"	5	30 HP	418 lbs.	\$699
BSXEB72	6' / 72"	6	35 HP	470 lbs.	\$849
BSXEB84	7' / 84"	7	35 HP	521 lbs.	\$959

BOX SCRAPERS

Heavy Duty



These heavy duty series of box scrapers are available in widths up to 8'. They are ideal for the professional landscaper or farmer. They come complete with hinged rear moldboard for smoother grading and front and rear cutting edge with scarifier shanks. Category 1 pins on 5' and 6' models. Category 2 pins on 7' and 8' models. Horsepower rating of 30 to 90 HP.

- * Solid welded frame with welded A-Frame
- * Radius formed moldboard for efficient loading and unloading
- * High clearance scarifier bar for less trash build up
- * Hinged free floating rear cutting edge for smoother grading
- * HP Requirements: 30-90
- * Moldboard height 18"
- * Depth 21-1/2"
- * Two heat treated 1080 grade 1/2" x 6" reversible cutting edges
- * 3/8" thick end plates

MODEL	WIDTH	# SHANKS	LOAD CAPACITY	WEIGHT	LIST PRICE
TB260	5'	5	17.50 Cu. Ft.	586 lbs.	\$1229
TB272	6'	6	21.00 Cu. Ft.	661 lbs.	\$1389
TB284	7'	8	24.50 Cu. Ft.	841 lbs.	\$1499
TB296	8'	9	28.00 Cu. Ft.	904 lbs.	\$1699

BOX SCRAPERS

HYDRAULIC RETRACTABLE

TB30 Series



Tufline's TB30 series hydraulic retractable scarifier box blades are designed to break through tough ground and easily handle a variety of earth-moving jobs. The hydraulic scarifier bar makes adjustments from the operator's seat convenient. The scarifier bar is constructed of heavy duty welded mast and tubular reinforced steel for durability. The large capacity steel box has a dual sided hinged tailgate to allow for scraping, leveling, and back filling. The cutting edges are 1/2" x 6" steel and are reversible for extended life. The blade is 20" high and the end plates are 3/8" thick. 5' & 6' models are Cat. I – 3 Pt. hitch, 7' & 8' models are Cat. I/II – 3 Pt. hitch. Includes hydraulic cylinder & hose kit.

- * **Solid welded frame with welded A-Frame**
- * **Radius formed moldboard for efficient loading and unloading**
- * **High clearance hydraulically operated scarifier bar**
- * **Hinged free floating rear cutting edge for smoother grading**
- * **Two heat treated 1080 grade 1/2" x 6" reversible cutting edges**
- * **3/8" thick end plates**
- * **Hi-strength adjustable scarifier shanks**
- * **Designed for up to 80 HP**
- * **Moldboard height 20"**
- * **Box depth 22"**

MODEL	WIDTH	# SHANKS	LOAD CAPACITY	WEIGHT	LIST PRICE
TB3060H	5'	6	21.8 Cu. Ft.	725 lbs.	\$2869
TB3072H	6'	6	26.2 Cu. Ft.	815 lbs.	\$3229
TB3084H	7'	8	30.5 Cu. Ft.	1052 lbs.	\$3499
TB3096H	8'	8	34.9 Cu. Ft.	1146 lbs.	\$3699

BOX SCRAPERS

Hi-Capacity without Scarifiers



These box scrapers without scarifiers by **MONROE TUFLINE** are ideal for several applications. Use them for poultry houses, dairy barns and snow removal.

- * Solid welded frame with welded A-Frame
- * Radius formed moldboard for efficient loading and unloading
- * One heat treated 1080 grade 1/2" x 6" reversible cutting edges
- * Designed for up to 75 HP
- * Moldboard height 25"
- * Box depth 36"
- * Cat. 1 and 2, 3 Pt. hitch

MODEL	WIDTH	CAPACITY	WEIGHT	LIST PRICE
PHB84	7'	44 Cu. Ft.	684 lbs.	\$1349
PHB96	8'	50 Cu. Ft.	748 lbs.	\$1439

OPTIONS:

MODEL	DESCRIPTION	WEIGHT	LIST PRICE
SSPHB	Adjustable skid shoes (pair)	20 lbs.	\$115

BOX SCRAPER

CBS Series



The Monroe Tufline CBS Series corral box scraper takes the proven Tufline box scraper series to another level. These heavy duty implements are ideal for cleaning barn lots, poultry house, snow removal and general land leveling and grading. The CBS Series box scraper is constructed of 4" square tubing, 1/4" moldboard with 1/2" x 6" reversible cutting edge, and 3/8" endplates.

- * **Constructed of 4" Square Tubing**
- * **1/4" Thick Moldboard**
- * **3/8" Thick End Plates**
- * **Heat Treated 1080 Grade 1/2 X 6" Reversible Cutting Edge**
- * **27" High x 36" Inside Depth**
- * **Cat. I or II 3 Pt. hitch**

MODEL	DESCRIPTION	HP REQ'D	CAPACITY	WEIGHT	PRICE
CBS84	7' box scraper	35-80 HP	44 Cu. ft	725 lbs	\$659
CBS96	8' box scraper	45-100 HP	50 Cu. ft	815 lbs	\$1789
CBS120	10' box scraper	55-120 HP	60 Cu. ft	1010 lbs	\$2059

BOX SCRAPER PULL TYPE



The Monroe Tufline pull type box scraper takes the proven Tufline box scraper series to another level. These heavy duty implements are ideal for cleaning barn lots, driveway grading, filling pot holes and general land leveling and grading. With tilting ability this is an excellent machine for crowning gravel roads or lanes, shaping slopes or cutting ditches.

- * **Constructed of 4" Square Tubing**
- * **1/4" Thick Moldboard**
- * **3/8" Thick End Plates**
- * **Heat Treated 1080 Grade 1/2 X 6" Reversible Cutting Edge**
- * **Includes Hydraulic Cylinders and Hoses**
- * **Tilting Ability**
- * **Clevis Hitch**
- * **9.5L x 15" Implement Tires**
- * **Includes Implement Tongue Jack**

MODEL	DESCRIPTION	HP REQ'D	CAPACITY	WEIGHT	PRICE
DS196T	8' box scraper	35-80 HP	44 Cu. ft	1300 lbs	\$4889
DS1120T	10' box scraper	45-100 HP	50 Cu. ft	1450 lbs	\$4999
DS1144T	12' box scraper	55-120 HP	60 Cu. ft	1600 lbs	\$5169



Has a Manure Spreader to fit your Operation?



Heavy Duty Models are available in 235,270, 310, 430, 560, and 660 bushel sizes.



Hydraulic Push 425 and 550 bushel spreaders feature either vertical or horizontal beaters.



"Top Shot" Side Discharge Manure Spreaders are available in 2000, 2600, 3400 and 4200 gallon models with the Optional Digi-Star Nutrient Tracker Scale System!

LAND PLANES

LP Series



Tuflines's LP Series land planes are ideal for gravel road reconditioning, driveway grading, pot hole filling, and general land levelling and grading. The LP series offers high strength reversible, double bevel cutting edges for unique dual blade grading performance. Constructed of heavy 3" square tubing, 3/16" thick plate & channel make the main frame rugged. Models 5' & 6' are Cat. I, 3 Pt. hitch. Models 7' & 8' are Cat. I - II, 3 Pt. hitch.

MODEL	WIDTH	WEIGHT	LIST PRICE
LP160	5'	482 lbs.	\$1269
LP172	6'	532 lbs.	\$1389
LP184	7'	598 lbs.	\$1429
LP196	8'	642 lbs.	\$1479



LP2 Series

Available with high strength alloy steel scarifier shanks for breaking compact ground. Constructed using 4" X 4" x 3/8" square tubing, along with 60" x 18" x 1/4" thick side plates.

MODEL	WIDTH	SHANKS	HITCH	WEIGHT	PRICE
LP284S	7'84"	4	CAT I & II	825 lbs	\$2339
LP296S	8'96"	6	CAT I & II	955 lbs	\$2629
LP2120S	10'120"	8	CAT II	1035 lbs.	\$2899
LP2144S	12'144"	10	CAT II	1325 lbs.	\$3089

POWERED LANDSCAPE RAKES



PTC Model for 3 Pt. Hitch



PSS Model for Skid Steer



PXS Model for "Mini" Skid Steer

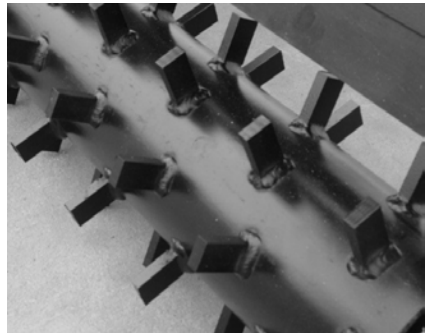

Sabre Tooth Rotor

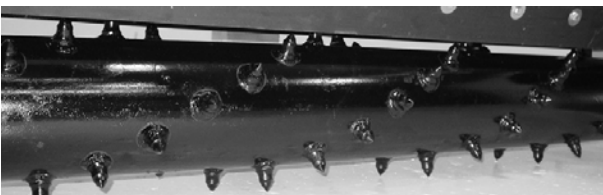

Carbide Rotor

POWERED LANDSCAPE RAKES



WORKSAVER's new Powered Landscape Rakes, remove debris or sod to prepare a seedbed surface to create a new lawn or renovate an existing lawn. These powered landscape rakes also pulverize and set grade on new construction sites. Models available in 3', 4', 5' & 6' working widths to fit mini/compact skid steers. 6', 7' & 8' for standard skid steers. 5', 6', 7' & 8' for tractors with 3 Pt. hitch 540 RPM PTO. Rakes are available with your choice of 2" "SABRE TOOTH" rotors or 1-3/4" "CARBIDE TOOTH" rotors. Replaceable bearing housings and triple sealbearings provide durability and serviceability. Call your dealer for other models and sizes not listed.

- * Working widths up to 8 ft. available
- * Available with your choice of 2" "Sabre Tooth" or 1-3/4" "Carbide Tooth" rotors
- * Quick flip (self storing) side shields allowing ease of wind rowing rocks and debris
- * Flip up gauge wheels with pneumatic tires
- * #80 roller chain drive, H.D. models double #80 chain drive
- * Environmentally friendly dry chain case
- * Replaceable bearing housing with triple sealed bearings
- * Standard Manual Angle adjustment, optional hydraulic angle kits available
- * Adjustable material bar
- * 540 RPM PTO models come with slip clutch PTO, and Cat. I, 3 Pt. Hitch
- * Hydraulic models to fit skid steers come with hydraulic hoses with connect under pressure couplers
- * Optional Skid shoes available

MODEL	DESCRIPTION	WEIGHT	LIST PRICE
PXS410ST	4 ft. with "Sabre Tooth" rotor universal "mini" skid steer mount	526 lbs.	\$7399
PSS620ST	6 ft. with "Sabre Tooth" rotor universal skid steer mount	832 lbs.	\$8369
PSHD865ST	8 ft. with "Sabre Tooth" rotor universal skid steer mount	1145 lbs.	\$10,959
PTC525ST	5 ft. with "Sabre Tooth" rotor 3 Pt. hitch PTO	627 lbs.	\$7599
PTC725ST	7 ft. with "Sabre Tooth" rotor 3 Pt. hitch PTO	699 lbs.	\$8599

OPTIONS:

MODEL	DESCRIPTION	LIST PRICE
360525	Pair of skid shoes mounts to side shield fits all models	\$149
360640	Hydraulic angle kit for PXS models with 2 sets of remotes	\$1149
360779	Hydraulic angle kit with solenoid for PSS/PSHD models with one set of remotes	\$1749

LANDSCAPE RAKES



DCR Model



ATV Landscape Rake on page 100



LRHD Model

These landscape rakes are quality built by **WORKSAVER**. With horsepower ratings up to 25 HP on the 4' and 5', 40 HP on the 6' and 7', and 60 HP on the HD 7' and 8' models, these units are built to last. Units come with heat treated steel spring teeth and all are solid welded for extra strength. Cat.I, 3 Pt. hitch. Gauge wheels are optional.

- * 1" x 5/16" x 27" tines
- * 5 backfill angle positions (DCR & MCR)
- * 5 forward angle positions (DCR & MCR)
- * 7 backfill angle positions (LRHD)
- * 7 forward angle positions (LRHD)
- * Turns 360°

MODEL	WIDTH	HP REQ'D	WEIGHT	LIST PRICE
DCR4	4'	25	124 lbs.	\$589
DCR5	5'	25	134 lbs.	\$669
MCR6	6'	40	187 lbs.	\$769
MCR7	7'	40	199 lbs.	\$799
LRHD7	7'	60	330 lbs.	\$1199
LRHD8	8'	60	365 lbs.	\$1279

OPTIONS:

MODEL	DESCRIPTION	LIST PRICE
SGW10	Single gauge wheel package (for DCR, MCR)	\$275
DGW20	Double gauge wheel package (for MCR7, LRHD)	\$499

MIXER - PTO

3 Pt. Hitch & Skid Steer Hydraulic



580



SS590

These mixers by **WORKSAVER** are available in both 3 Pt. hitch and skid steer mount models and are ideal for all mixing applications. Both models come with a 5 Cu. Ft. capacity (1 bag mix).

Cat. I, 3 PT. HITCH

- * 540 RPM PTO
- * Hydraulic top link cylinder provides positive dump control
- * # 40 roller chain drives mixing drum
- * Two piece steel drum with internal mixing paddles

SKID STEER MOUNT

- * Fits "Universal Style" skid-steer attachment system
- * Hydraulically driven gear box
- * Minimum hydraulic flow required 8 GPM
- * Gear ratio 3.18 : 1
- * Internally welded mixing paddles for proper mixing
- * Includes flow control valve (On-Off) for easy operation
- * Hydraulic hoses included with connect under pressure flat faced couplers

MODEL	DESCRIPTION	WEIGHT	LIST PRICE
580	3 Pt. PTO mixer	215 lbs.	\$1479
SS590	Skid steer hydraulic	395 lbs.	\$3975

CARTS

POLY



These carts will perform a variety of tasks safely, reliably and efficiently. The clean ergonomic design and sturdy construction make these carts perfect for hauling yard refuse, firewood, topsoil, sand and gravel or any other job you need moved or carried. Available in steel or poly bed construction.

Model TC10P

List Price: \$185

- * 600 lb. weight capacity
- * Convertible push or tow dump cart
- * Fold behind tongue / drawbar assembly
- * One piece rustproof poly bed
- * Bed Size 30.5" W x 41" L x 11" H
- * Tire size 4.80" x 8" turf tire
- * Weight 67 lbs.



Model 450464

List Price: \$485

- * 800 lbs./ 12 cu.ft. Capacity Tow cart
- * One Piece Poly Structural Foam Construction
- * Bed Size 58" L x 15" H x 41" W
- * Tire Size 15" x 6"
- * Foot lever Dumping Mechanism
- * Weight 110 lbs.



Model 450175

List Price: \$489

- * 650 lbs. load capacity
- * Durable poly construction
- * Bed size 30"W x 45"L x 12"H
- * 18" x 6.5" all-terrain pneumatic tires
- * Wheels feature needle bearings and grease zerks
- * Weight 93 lbs.



See additional carts on following pages

CARTS STEEL



Model TC1018

List Price: \$219

- * 750 lbs. load capacity
- * Bed size 18 ga. 31"W x 42"L x 13"H
- * Tire size 16" x 4.8" x 8" pneumatic turf tires
- * Solid 3/4" dia. axle
- * Removeable tailgate
- * Easy single lever dump release
- * Weight 99 lbs.



Model TC17

List Price: \$369

- * 1500 lbs. load capacity
- * Bed size 16 ga. 37"W x 59"L x 16"H
- * Tire size 16" x 6.5" pneumatic turf tires
- * Removable tailgate
- * Easy single lever dump release
- * Weight 171 lbs.



Model TC174

List Price: \$549

- * 2000 lbs. load capacity
- * 4 wheel, front steerable axle
- * Bed size 16 ga. 37"W x 59"L x 16"H
- * Bed design: one piece
- * Tire size 16" x 6.5" - 8" pneumatic turf tires
- * Removable tailgate
- * Solid 3/4" steel axle
- * Weight 224 lbs.



See additional carts on following pages

ATV DUMP CARTS

STEEL



450240ATV



450350

AGRI-FAB'S heavy duty ATV dump carts are tough enough to handle your large loads at speeds up to 20 MPH. ATV carts come with needle bearing wheels, with grease zerks, on 1" diameter high carbon steel axles. Removable tailgate.

MODEL	DESCRIPTION	WEIGHT	LIST PRICE
450240ATV	Single axle with 18 x 6.50-8 all terrain pneumatic tires 1200 lb. capacity Bed size 18 ga., 46"L x 34"W x 14"H	147 lbs.	\$589
450350	Tandem Axle 1000 lb. Cap. Bed Size, 16 ga. 32.5" W x 61" L x 12" H includes steel tube railing kit comes with 18 x 9.50 all-terrain pneumatic tires	230 lbs.	\$959

TINE DE-THATCHERS

Pull Type



De-thatching is very important in environmentally conscious lawn care. These de-thatchers by **AGRI-FAB** do a gentle job of bringing matted layers of thatch and large clippings to the surface for a healthy lawn.

- * Twenty 3/16" heated tines on 40"
- * Twenty four tines on 48"
- * 40" and 48" working width available
- * 7" x 1.5" semi-pneumatic tires

MODEL	WIDTH	WEIGHT	LIST PRICE
4502941	40"	33 lbs.	\$109
4502951	48"	37 lbs.	\$159

LAWN SWEEPERS



- * 42" wide lawn sweep
- * 12.9 cu. ft. capacity
- * 10" diameter brush
- * 10-1/2" rubber tire

- * 48" wide lawn sweeper
- * 14.9 cu. ft. capacity
- * 10" diameter brush
- * 10-1/2" rubber tire

MODEL	DESCRIPTION	WEIGHT	LIST PRICE
TL31108	42" Pull type lawn sweeper	77 lbs.	\$309
TL31109	48" Pull type lawn sweeper	86 lbs.	\$359

LAWN SWEEPER SMARTSWEEP



The NEW SmartSWEEP from Agri-Fab is designed to make sweeping up yard debris easier than ever. This unit doesn't skip, solving the #1 consumer frustration with current lawn sweepers. 25 cu. ft. hopper capacity. Exclusive patent pending offset hitch design allows users to simultaneously cut and sweep lawn clippings or leaves. Exclusive, patent pending ergonomic dumping mechanism, no more rope to pull. One button brush height adjustment, adjusts just the brush, not the whole unit.

- * 44" sweeping width
- * 25 cu.ft. hopper capacity
- * #4 - 12" diameter brushes
- * Offsetable hitch
- * Ergonomic dumping mechanism
- * One button brush height adjustment
- * Design allows sweeper to collapse for compact storage

MODEL	DESCRIPTION	WEIGHT	PRICE
450492	44" SmartSWEEP	94 lbs.	\$459

OPTIONS:

MODEL	DESCRIPTION	WEIGHT	LIST PRICE
4503433	Front mount tine de-thatcher fits above "TOW TYPE" sweepers	23 lbs.	\$95

LAWN VACS



55249



55188

For any size yard, Agri-Fab's **Mow-N-Vac** or **Chip-N-Vac** offer proven performance. 80 MPH worth of suction provides enough power to collect large quantities of grass, leaves, twigs, pine needles, etc. that can be dumped effectively with any of Agri-Fab's vac systems. All units include a safety engine shut-off which prevents accidental engine start-ups, a universal fit mower deck adapter. Units fit only right hand discharge mid-mount mowers. Optional 65640 hose kit is required for front mount zero turn mowers.

MODEL	DESCRIPTION	WEIGHT	LIST PRICE
55188	Hard Top Mow-N-Vac with 205cc B&S Intek engine. Large 26 bushel/32 cu.ft. capacity Includes cart with durable vented hard top design.	340 lbs.	\$1829
55249	Hard Top Chip-N-Vac with 205cc B & S engine. Large 26 bushel/32 cu.ft. capacity, chips up to 2" Dia. brush. Includes cart with durable vented hard top design	384 lbs.	\$2099

OPTIONS:

MODEL	DESCRIPTION	WEIGHT	LIST PRICE
450253	5" x 12" long, remote hose kit for vacuuming flower beds and from under trees	19 lbs.	\$219
65640	Hose extension kit with adapter for zero turn. Front mount mower deck		\$99

SMARTLINK ATTACHMENTS



The NEW SmartLINK system from Agri-Fab allows users to switch from one lawn implement to another in seconds without tools. Purchase the "master platform" and then any of the four different attachments, 40" TURF SHARK™ Curved Blade Aerator, 40" Core/Plugger Aerator, 40" Tine dethatcher or 40" x 18" Poly Lawn Roller as required or purchase all five pieces. Dethatch, roll, spike or aerator your lawn with the pull type master platform that can be easily hooked to any lawn tractor. SmartLINK lawn care system provides unprecedented versatility and can be easily stored.

- * Master platform provides durable heavy gauge steel deck and drawbar
- * Universal hitch fits any lawn tractor
- * Rustproof aerator/core knives allows air, water and nutrients to reach into the soil
- * Patented Turf Shark™ spike aerator designed for thorough soil penetration without messy soil plugs
- * Tine dethatcher effectively loosens and lifts thatch for healthier lawn growth
- * 40" x 18" poly lawn roller weighs up to 400 lbs, levels sod, packs fresh seeding, levels frost heaving ground and more

MODEL	DESCRIPTION	WEIGHT	LIST PRICE
450453Q	Master Platform with ALL 4 Attachments	158 lbs.	\$649
450473	Master Platform	60 lbs.	\$179
450474	40" Core/Plugger Aerator	29 lbs.	\$1115
450458	40" Turf Shark™ Curved Blade Spike Aerator	23 lbs.	\$95
450457	40" Tine Dethatcher	19 lbs.	\$105
450459	40" Poly Lawn Roller Capacity 400 lbs	27 lbs.	\$169

CORE /PLUG AERATOR Pull Type

Agri-Fab
Lawn Care Made Easy

**YARD
COMMANDER**



450299



TL31202

Core aerating is increasingly important in aesthetically and environmentally conscious lawn care. These core aerators by **AGRI-FAB** are perfect for highly compacted clay soil conditions allowing seed, fertilizer, air and water to reach deep into the lawns roots. These core aerators by **AGRI-FAB** and **YARD COMMANDER** are perfect for highly compacted clay soil conditions allowing seed, fertilizer, air and water to reach deep into the lawns roots.

450299

- * 48" working width
- * 3" aeration depth
- * 32 heat treated points
- * Tray capacity 140 lbs.
- * 10" x 4" pneumatic tires
- * Single hand lift lever

TL31202

- * 60" working width
- * 3" aeration depth
- * 40 heat treated points
- * Tray capacity 200 lbs.
- * 10" x 4" pneumatic tires
- * Single hand lift lever

MODEL	DESCRIPTION	WEIGHT	LIST PRICE
450299	Agri-Fab 48" 32 plug core aerator	91 lbs.	\$259
TL31202	Yard Commander 60" 40 plug core aerator	136 lbs.	\$309

SPIKE AERATOR



Aeration allows water, sunlight, fertilizer and nutrients to reach the grass roots for a healthy lawn. The curved spike aerators spike wheel provides the perfect amount of penetration and soil plug removal without the mess associated with plug aerators.

- * **Simple to use single lever wheel engaging for easy transport**
- * **40" Weight tray**
- * **12-9" rust-resistant, galvanized curved discs**

MODEL	DESCRIPTION	WEIGHT	LIST PRICE
450369	40" "Turf Shark" Curved Spike Aerator	54 lbs.	\$199

LAWN ROLLERS



450216 Shown (Steel)



450269 Shown (Poly)

Uneven ground from frost heaving, newly sewn lawns or sod that just needs to be packed down, are ideal jobs for these **AGRI-FAB** lawn rollers. These steel or poly tow rollers can be used for light or heavy duty performance.

MODEL	ROLLER DRUM	WEIGHT W/WATER	SHIPPING WEIGHT	LIST PRICE
450269	POLY 18" dia. x 48" wide	550 lbs.	54 lbs.	\$259
LRP2448B	POLY 24" dia. x 48" wide	825 lbs.	82 lbs.	\$289
450179	STEEL 24" dia. x 36" wide	640 lbs.	110 lbs.	\$269
450216	STEEL 24" dia. x 48" wide	910 lbs.	170 lbs.	\$349

DRUM SPIKER



The YARD COMMANDER Tow Behind Drum Spiker is a versatile implement for Aerating and lawn compaction of frost heaves in the spring of the year. Helps nutrients get into soil and down to the roots. This unit can be attached to any lawn and garden tractor or ATV.

- * Pull/Tow Type
- * 60" x 14" Diameter Drum
- * 126 Steel Spikes Penetrates the Ground up to 2-1/2"
- * Drum holds 31 Gallons of Water
- * Adds 460 lbs. of Weight

MODEL	DESCRIPTION	WEIGHT	LIST PRICE
TL31112	60" Drum spike aerator	186 lbs.	\$499

SPREADERS

Broadcast - Push Type



450388



4502142
w/65353

Broadcast spreaders spread everything from fertilizer, seed, ice melters and more. Solid construction and reliable design ensures even and continuous flow and spread of materials, eliminating streaks. Hoppers constructed of weather resistant polyethylene.

MODEL	DESCRIPTION	WEIGHT	LIST PRICE
450388	85 Lb. Capacity 10" x 4" pneumatic tires. Up to 10' Spread width	20 lbs.	\$89
4502142	100 Lb. Capacity 10" x 4" pneumatic tires. 8' to 10' spread width	33 lbs.	\$169

OPTION:

MODEL	DESCRIPTION	LIST PRICE
65353	Deflector skirt for ice melter	\$29
40883	85 lb - 100 lb hopper cover	\$19

SPREADERS

Broadcast - Tow Type



4502152



450315

Broadcast spreaders spread everything from fertilizer, seed, ice melters and more. Solid construction and reliable design ensures even and continuous flow and spread of materials, eliminating streaks. Hoppers constructed of weather resistant polyethylene. On/Off Control is accessible from tractor seat

MODEL	DESCRIPTION	WEIGHT	LIST PRICE
450315	85 lbs. Cap 10" x 4" pneumatic tires Up to 10' Spread Width	17 lbs.	\$89
4502152	100 Lb. Cap. 10" x 4" pneumatic tires 8' to 10' spread width	33 lbs.	\$169

OPTION:

MODEL	DESCRIPTION	LIST PRICE
65353	Deflector kit for ice melter	\$29
40883	85 lb - 100 lb hopper cover	\$19

SALT SPREADER

Broadcast

Push-Type



This spreader was specifically designed to spread ice salt, ice melter and more. Solid construction and reliable design ensures even and continuous flow and spread of materials, eliminating streaking. Hopper constructed of weather resistant polyethylene. Stainless steel frame, axle and hardware.

- * 125 lb. Capacity
- * Push Type
- * Spread Width 10' – 12' depending on material being spread
- * 6.00 – 6 pneumatic turf tire (14" diameter)
- * Poly Hopper
- * Stainless Steel Frame & Spreader Plate, Axle & Hardware
- * H.D. Stainless Steel Gear
- * Includes grate/screen and weatherproof cover
- * Deflector Kit to reduce spread width
- * Rate setting control on handle for precise adjustments

MODEL	DESCRIPTION	WEIGHT	LIST PRICE
TL31520	125 lb. capacity, push type 6.00 x 6 pneumatic tires c/w screen/grate weather cover & deflector kit	41 lbs.	\$419

SPREADER

Broadcast

Pull-Type



Broadcast spreaders spread everything from fertilizer, seed, ice melter and more. Solid construction and reliable design ensures even and continuous flow and spread of materials, eliminating streaking. Hopper constructed of weather resistant polyethylene. On/off control is accessible from tractor seat.

- * 175 lb. Capacity
- * Spread Width 10' – 12' depending on material being spread
- * 6.00 x 6 pneumatic tire
- * Poly Hopper
- * Rust Proof Spreader Plate
- * H.D. Aluminum Gear
- * Includes grate/screen and weatherproof cover

MODEL	DESCRIPTION	WEIGHT	LIST PRICE
TL31510	175 lb. capacity, tow type 6.00 x 6 pneumatic tires c/w screen and weather cover	53 lbs.	\$309

SPREADERS

SmartSPREADER



450463



450462

- * 130 lb. capacity
- * Unique, user friendly spreader-setting knob for precise fertilizer application
- * Spring loaded ON/OFF lever

MODEL	DESCRIPTION	WEIGHT	LIST PRICE
450462	SmartSPREADER Push	37 lbs.	\$239
450463	SmartSPREADER Tow	37 lbs.	\$239

OPTION:

MODEL	DESCRIPTION	LIST PRICE
41316	Hopper cover	\$22
67660	PRO KIT for 450462 Includes adjustable shield, cushion handles & hopper cover	\$89
67663	SPREADER GRATE KIT for 450462	\$59

SPREADERS

Broadcast 12 Volt



DMSTR12V22



ATVDMS12V

The Fimco ATV spreader has a 2.2 cubic foot poly hopper which has a capacity of up to 145 lbs. depending on type of material. Stainless steel radial 6 blade fan/spinner can spread material up to 45 feet (depending on type of material). Can be used with fertilizer, seed, powders, granular, insecticides, fungicides and herbicides & ice melter.

- * 2.2 cu. ft. rust proof poly hopper
- * Up to 145 lb. capacity
- * 5 ft. to 45 ft. variable spread width
- * Stainless steel radial 6 blade fan / spinner
- * 12 volt motor with variable speed control with On-Off switch
- * Universal ATV mounting
- * Pull type tire size 15/600 x 6

MODEL	DESCRIPTION	WEIGHT	LIST PRICE
ATVDMS12V	ATV mounted spreader	56 lbs.	\$449
DMSTR12V22	ATV pull type spreader	59 lbs.	\$479

OPTIONS:

MODEL	DESCRIPTION	LIST PRICE
5058193	Clear hopper cover	\$10
5301901	2" receiver hitch	\$109

DROP FERTILIZER SPREADER



450288

The Agri-Fab drop spreader is the proper tool for overseeding, weed control, fertilizing and more. You can count on the Agri-Fab spreader to help. Designed for easy operation and even coverage, our spreaders will give you great results time after time.

- * 175 lbs. capacity
- * 42" spread width
- * 3/4" axle
- * Covers approx. 40,000 sq. ft.
- * Premium galvanized steel agitator.
- * Spreader settings for a multiple of materials.
- * Ground Drive

MODEL	DESCRIPTION	WEIGHT	LIST PRICE
450288	Drop fertilizer spreader 14" x 4" pneumatic tires	45 lbs.	\$279

SPIKER SEEDER DROP SPREADER



The YARD COMMANDER Tow Behind Spiker/Seeder/Drop Spreader is a versatile implement for spreading seed, fertilizer, or for over seeding lawns. This unit can be attached to any lawn and garden tractor or ATV.

- * Tow Type
- * 175 lb.(80 L) capacity
- * Approximate coverage 40,000 sq. ft.
- * Spread Width 40"
- * Poly Hopper is Rust Proof
- * 12 Spike Wheels, 7" Diameter
- * 3.50 - 4 x 10" Pneumatic Tires

MODEL	DESCRIPTION	WEIGHT	LIST PRICE
TL31519	Spiker/Spreader/Over Seeder	70 lbs.	\$349

SPREADERS

Baby-Hop

Ground Driven



Easy connecting pull type hitch, ground controlled distribution, and rugged construction makes the **BEFCO** Baby-Hop spreader the perfect companion for your ATV, riding mower or small garden tractor. Ideally suited for even distribution of fertilizer, seed, salt and dry sand. Baby-Hop spreaders come complete with:

- * One piece seamless painted steel hopper
- * Even spread left-center-right pattern
- * High flotation air tires
- * 103-130: 13x5.00-6
- * 106-130: 16x6.50-8
- * Easy connecting pull type hitch
- * Sturdy tubular frame
- * Hopper levelling adjustment
- * Sealed heavy duty gearbox

MODEL	HOPPER CAPACITY CU.FT/LBS	SWATH SPREAD	WEIGHT	LIST PRICE
103-130	3.5 / 226	20'	62 lbs.	\$749
106-130	5.6 / 362	20'	84 lbs.	\$999

NOTE: Poundage capacity calculated at 13-13-13 fertilizer weight of 64 Lbs./Cu. Ft.

OPTIONS:

MODEL	DESCRIPTION	LIST PRICE
AA1-120	Deflector shield-reduces spreading width to approximately 4'	\$105

SPREADERS

Spin Type

Steel



These quality spreaders are designed for tractors from 16 to 30 HP, 540 PTO RPM, Category 1, 3 Pt. hitch. Ideal for distribution of fertilizer, seed, salt, dry sand and much more. Spreaders come complete with:

- * **HP Requirements: 16-30, 540 RPM**
- * **One piece seamless painted steel hopper**
- * **Three different spread patterns**
- * **Heavy duty shielded PTO shaft (1-3/8" ASAE Cat. 1)**
- * **Sturdy tubular frame**
- * **Selective double gate opening**
- * **Sealed heavy duty gearbox**
- * **Fixed agitator**
- * **Cat. 1, 3 Pt Hitch on all models**

MODEL	HOPPER CAPACITY		WEIGHT	LIST PRICE
	CU.FT.	LBS		
203-120	3.5	226	81 lbs.	\$749
206-121	4.8	311	102 lbs.	\$769
209-121	10.6	678	125 lbs.	\$809
212-121	17.6	1130	136 lbs.	\$849

NOTE: Poundage capacity calculated at 13-13-13 fertilizer weight of 64 Lbs./Cu. Ft.

OPTIONS:

MODEL	DESCRIPTION	LIST PRICE
009-9524	Deflector shield fits model 203 & 206	\$99
009-9979	Tumbling style agitator 203 model only	\$89
009-9638	Deflector shield fits model 209 & 212	\$195
009-9978	Tumbling style agitator for 206, 209 and 212	\$89
AA4-120	Siderow discharge for model 209 & 212 only	\$449

SPREADERS

SPIN TYPE - POLY HOPPER



BRI poly hopper spreaders are available in two models, Cat. I 3 Pt hitch, 540 RPM PTO. Bottom opening gates ensure a constant and accurate flow of material to spinner. Variable positioning gate openings and fin adjustments allow material to drop on different positions of the spinning disc, therefore giving a left-right-center spread pattern. Maintain a constant homogenous blend of any and all combinations of fertilizers, seeds, fungicides, herbicides, etc. with the BLENDER option. The blender option offers a unique fountain blending system which keeps a consistent mix of any and all product being spread. Only available on model SSP400

- * **Durable no-rust Poly Hopper**
- * **Cat. I 3 Pt. Hitch**
- * **540 RPM PTO**
- * **Simple adjustable left-right-center spread pattern**
- * **Galvanized spin disc with multi-positioning adjustable fins**
- * **Maximum spread pattern 49 feet depending on material being spread**

MODEL	DESCRIPTION	WEIGHT	LIST PRICE
SSP250	575 LB. / 196 Litres	123 lbs.	\$649
SSP400	860 LB. / 293 Litres	130 lbs.	\$675

OPTIONS:

MODEL	DESCRIPTION	LIST PRICE
SBL001	Blender attachment for SSP400 only	\$399

SPREADERS

Turbo Hop 3 Pt.



301-350 Shown



303-600 Shown

Turbo Hop spreaders are designed for tractors from 20 to 60 HP, 540 PTO RPM, with a maximum spread swath of 40'-46'. Ideal for distribution of fertilizer, seed, salt, dry sand where accuracy and precision in application is needed. Turbo Hop spreaders come complete with:

- * **HP Requirements: 20-60, 540 RPM**
- * **Polyethylene hopper**
- * **Spreader spouts made of nylon and reinforced fiberglass**
- * **Stainless steel opening control disc**
- * **Cast steel anti-wear agitator**
- * **Heavy duty shielded PTO shaft (1-3/8" ASAE Cat. 1)**
- * **Sturdy tubular frame**
- * **Micrometric flow control adjustment**
- * **Heavy duty cast steel gearbox in oil bath**
- * **301-350 Cat I, 3 Pt. hitch**
- * **303-999 Cat I & II, 3 Pt. hitch**
- * **303-600 Cat I & II, 3 Pt. hitch**

MODEL	HOPPER CAPACITY	SPREAD	WEIGHT	LIST PRICE
	CU.FT./LBS	WIDTH		
301-350	12.4 / 792	17'-47'	250 lbs.	\$2799
303-600	22.5 / 1168	17'-47'	321 lbs.	\$3769
303-999	42.4 / 2205	17'-47'	343 lbs.	\$4499

OPTIONS:

MODEL	DESCRIPTION	LIST PRICE
AZ1-301	Agitator extension for 301-350 model only	\$209
AZ2-300	Sand and salt spout (all models)	\$329
AZ3-303	Hydraulic control for 303-600 & 303-999	\$635
AZ4-300	Rubber insert for damp material (all models)	\$119
AZ6-303	Filter grill for 303-999 models only	\$459
AZ7-303	Agitator extension for 303-600 & 303-999	\$195
AZ8-300	Left & right directional attachment (all models)	\$79

SPREADER

3 Pt. Hitch, 12 volt



The FIMCO 3 Pt. hitch spreader features a tough, corrosion - resistant 5.0 cu.ft. / 200 lb. capacity poly hopper with a stainless steel radial six blade spreading fan. Adjustable slide gate allows you to control the amount of material you're spreading, and can be opened or closed with a simple turn of the on/off handle. The FIMCO spreader uses a variable-speed 12 volt motor (with on/off switch) that lets you change the spread width from 5 ft. to 45 ft. (depending on material being spread).

- * Poly Hopper
- * 5.0 Cu.ft. / 200 lb. capacity
- * CAT I, 3 Pt hitch
- * Stainless steel radial six blade spreader fan
- * 12 volt motor
- * Variable speed controller
- * Wiring harness to power supply

MODEL	DESCRIPTION	WEIGHT	LIST PRICE
DMS3PT12V50	Spreader 200 lb. capacity 12 volt	125 lbs.	\$595

ATV SEEDER & SPREADER



The WORKSAVER ATV Seeder & Spreader helps get a head start early in the season for seeding pastures or cover crops and fertilizers. The 12 volt electric ATV seeder has a 1 bushel poly hopper to promote longer life. The adjustable flow control mounted on the ATVK400 is easy to adjust and provides better control over material flow. Universal mounting fits most makes and models of ATV's.

- * 12 volt electric motor with variable speed control
- * 1 bushel poly hopper is translucent for easy monitoring of hopper material level
- * Snap-on lid to prevent seed from blowing out and keep moisture out
- * Proven 2-opening seed gate that closes tightly and reopened to the same setting
- * A mud and water shield to protect the spreader fan
- * Complete wiring harness with simple clips to fasten to battery terminals
- * Lightweight, high strength design allows operator to easily mount or dismount unit from ATV
- * Flow control lever and seeding chart is easily accessible to the operator
- * Universal mounting fits most makes and models of ATV's
- * Mounts to rear rack of ATV

MODEL	DESCRIPTION	WEIGHT	LIST PRICE
ATVK400	ATV Seeder & Spreader	42 lbs.	\$509

ZA-M FERTILIZER SPREADERS

ONLY AVAILABLE THROUGH STOCKING DEALERS



SBS – Soft Ballistic System

Mineral fertilizer needs to be gently handled to ensure a precise distribution and an exact placement to the plant over the entire working width. Fertilizer, which has been damaged while going through the spreader, will not be precisely distributed. The AMAZONE Soft Ballistic System is integrated into all ZA-M mounted spreaders where the agitator, metering components and spreading discs are all optimally matched to protect the fertilizer and ensure even distribution over the entire working width.

Stainless Steel Spreading System

The entire spreading system of the ZA-M spreaders is made from stainless steel: Hopper tips and agitator spirals. Entire base plates with setting rate slides and hydraulic shutters. Spreading discs with the spreading vanes
Fully enclosed deflector plates

Oil Bath Gearboxes

The oil bath gearboxes have proven to be the indestructible heart of the AMAZONE twin disc centrifugal spreader. Repetitive test procedures are conducted. They are maintenance free and provide integrated overload safety to prevent gearbox damage. Rate Adjustment: Simple – Reliable – Precise
The spreading rate and the working width are preselected from the extremely-comprehensive setting chart. Clear easy to read scales help you to set the spreading rate exactly using the shutter slide.

The Double Shutter Control System

The rate shutters and on-off shutters can be operated independently of each other. The double acting hydraulic slides ensure an instantaneous opening and closing of the shutters at ends of the field.

OM Omnia-Set Spreading Discs

The OM Omnia-Set spreading discs are equipped with pivoting spreading vanes that generate a spread pattern that is extremely precise and safe. With the aid of an easily readable scale that is in the users field of view, the spreading vanes can be adjusted easily and exactly without tools. AMAZONE provides comprehensive setting charts for all kinds of fertilizer and seed. The OM Omnia-Set spreading discs are made from stainless steel and are easily installed.

ZA-M FERTILIZER SPREADERS



Today's farmer and agricultural custom operators need fertilizer spreaders where, safety, accuracy and dependability come first. AMAZONE is safe in every respect: on the road, in the field, during adjustment and while spreading. It is not just about saving money, but also protecting the environment and ensuring safety on the road as well as accuracy in the field with accurate spreading of your fertilizer.

- * **Important Parts in Stainless Steel**
- * **Square Shallow Twin Tip Hopper**
- * **Indestructible Oil Bath Gearboxes**
- * **c/w Stainless Steel OM 24-36 Spreading Discs**
- * **Stainless Steel Guard Tube to Protect Spreading Discs**
- * **Spiral Agitators Ensure a Very Even Fertilizer Flow**
- * **Hydraulic Single Shutter Slide Control for the Right or Left Hand Side**
- * **Standard with Traffic Lights and Warning Plates**
- * **Filling Sieve against Foreign Particles**
- * **540 RPM PTO Shaft**
- * **CAT II 3 Pt. Hitch**
- * **Maximum Payload up to 6835 lbs. (3100kg)**
- * **Calibration Device for the Simple Check of the Pre-Adjusted Spread Rate**
- * **Comprehensive Setting Charts for all Types of Fertilizer**
- * **Calculation Disc Rule to Determine the Required Shutter Slide Position**
- * **Optional Spreading Disc, Hopper Extensions, Hopper Covers, Border Spreading Devices available**

MODEL	DESCRIPTION	WEIGHT (LBS.)	LIST PRICE
ZAM1501	1500 L / 395 gal capacity with 24' to 36' spreading disc	337 kg	\$8599

OPTIONS:

MODEL	DESCRIPTION	WEIGHT	LIST PRICE
S500	922782 500 L / 130 gallon hopper extension	27 kg	\$699
L1000	935040 1000 L / 265 gallon hopper extension	57 kg	\$1289
927784	Hopper cover for spreaders without extensions or with S500 hopper extensions only	26 kg	\$815
927785	Hopper cover for spreaders with L1000 extensions	29 kg	\$950
	OM Omnia-Set Spreading Discs (pair) OM10-12, OM10-16, OM18-24	12.5 kg	PRICE ON REQUEST
1733010	Boundry spread deflector Left Hand Side	5 kg	\$249

SPOT & ATV SPRAYER



LG15EC



ATV25700



15 Gal. Spot Sprayer

- * 15 Gal. (U.S.) corrosion resistant polyethylene tank
- * Full drain out capabilities with molded in drain port, cap & tether
- * Large sump pickup
- * 5" fill lid with tether
- * 12 volt (demand) diaphragm 1.0 GPM 35 PSI pump
- * 18" lever handgun with adjustable nozzle with 15 ft. of hose
- * Max. horizontal throw 25 ft.
- * Max. vertical throw 12 ft.

25 Gal. ATV Sprayer with Boom

- * 25 Gal. (U.S.) corrosion resistant polyethylene tank
- * Universal ATV mounting brackets
- * Full drain out capabilities with molded-in drain port, cap & tether.
- * 12 volt diaphragm demand style pump, 2.1 GPM. Pressure range 0 – 60 PSI
- * Adjustable Pressure
- * Pressure Gauge
- * 18" Handgun with adjustable nozzle & 15 ft. of hose
- * 7 Nozzle, 3 section folding boom 140" spray coverage Includes nozzles and screens

MODEL	DESCRIPTION	WEIGHT	LIST PRICE
LG15EC	15 gal. spot sprayer with hand gun & 15 ft. hose	18 lbs.	\$139
ATV25700	25 gal. ATV sprayer with 7 nozzle 3 section boom (140") with hand gun & 15 ft. hose	66 lbs.	\$479

ESTATE SPRAYERS

Tow Type



ATVTS6012V



TR30EX



TR40EX

- * Measured in U.S. gallon / litres
- * Corrosion resistant polyethylene tanks
- * Lower tank profile for improved stability
- * Full drain out capability with molded in drain port, cap & tether
- * Full length drain sump
- * Large pickup sump
- * 5" fill lid with tether
- * Both gallon (US) and litre fluid volume indicator
- * 30 gallon includes lever handgun with adjustable nozzle and 15ft of hose
- * 40 & 60 gal. includes deluxe pistol grip handgun with adjustable nozzle and 25ft of hose
- * 30 & 40 gallon: 12 volt 2.1 gpm, 60 psi diaphragm pump
- * 60 gal. 12 volt 3.8 gpm, 45 psi diaphragm pump
- * "On-Off" Switch
- * Includes spray boom (includes nozzles and screens):
 - 30 gallon, 2 nozzle 80" coverage
 - 40 gallon, 5 nozzle 100" coverage
 - 60 gallon, 7 nozzle 140" coverage

MODEL	DESCRIPTION	WEIGHT	LIST PRICE
TR30EX	30 gallon, 2 nozzle, 80" spray coverage 12V pump with 13" pneumatic tires	62 lbs.	\$419
TR40EX	40 gallon, 5 nozzle, 100" spray coverage 12V pump with 15/600 x 6 pneumatic tires	205 lbs.	\$859
ATVTS6012V	60 gallon, 7 nozzle, 140" spray coverage 12V pump, 18 x 9.5 x 8 pneumatic tires	295 lbs.	\$1399

Weights indicated are base machine weight, not shipping weight

ATV & UTV SPRAYERS



- * Corrosion resistant polyethylene tanks
- * Lower tank profile for improved stability
- * Full drain out capability with molded in drain port, cap & tether
- * Full length drain sump
- * Large pickup sump
- * 5" fill lid with tether
- * Both gallon (US) and litre fluid volume indicator
- * Includes 5 nozzle, 100" spraying width, 3 section folding boom
- * Includes deluxe pistol grip handgun with adjustable nozzle and 25 ft. of hose
- * 12 volt, 2.1 gpm, 45 psi diaphragm pump
- * Pressure gauge - adjustable pressure
- * "On-Off" switch
- * Steel skid type frame assembly

MODEL	DESCRIPTION	WEIGHT	LIST PRICE
UTL405	40 gal. UTV with 5 nozzle, 3 section boom 12 volt, 2.1 GPM pump. Mounts in rear box	117 lbs.	\$779

SPRAYER

3 Pt. Hitch



40 gal. Cat. I, 3 Pt. sprayer for sub-compact and compact tractors for the application of pesticides, herbicides, insecticides or fungicides. Four nozzle boom with 120" spray coverage, 3 section boom features break-away hinges for transport or striking objects such as trees or post when spraying.

- * 40 U.S. gallon polyethylene tank
- * 12 volt diaphragm demand style pump
2.1 gpm, 0-60 psi
- * Break away hinges on boom
- * 4 nozzle, 3 section Fold Behind Boom
- * 120" spray coverage
- * Deluxe pistol grip handgun with 15 feet of hose
- * Pressure gauge
- * 8 ft. lead wire with remote switch
- * Cat. I, 3 Pt. hitch

MODEL	DESCRIPTION	WEIGHT	LIST PRICE
LG403PT12V	40 gal. US 3 Pt hitch sprayer 12V pump, 120" spray coverage	80 lbs.	\$479

SPRAYER

3 Pt. Hitch



LG603PT



Spray Gun Kit



Pump

60 Gal. (U.S.) Cat. I 3 Pt hitch sprayer for compact tractors for the application of pesticides, herbicides, insecticides or fungicides. 3 section, 7 nozzle boom, fold behind, coverage 140" features break-away hinges on boom.

- * 60 U.S. Gallon Polyethylene tank
- * 7 Nozzle, 3 section fold behind boom
- * Comes with TP8002VP Spray tips
- * Break-Away Hinge on Boom
- * 140" Spray Coverage
- * 6 Roller Ni-Resist Pump with PTO Coupler
- * Deluxe pistol Grip Hand gun with 25' of hose
- * Single Manual Lever Valve Boom Control
- * Relief Valve for Pressure Adjustment
- * Pressure Gauge

MODEL	DESCRIPTION	WEIGHT	LIST PRICE
LG603PT	60 gal. US 3 Pt hitch sprayer with 6 roller Ni-Resist PTO pump	265 lbs.	\$1469

SPRAYER FOAM MARKERS

TrailLine



TJEV24



TJ15G



TJ1G

A foam marker can be a simple solution to mark your sprayed area through deposits of balls or ribbons of foam. It's the most common and economical way to avoid over or under application of crop protection chemicals. Kits include a 12 volt compressor, a solution tank, control box, and all the parts necessary for installation on any type of spraying equipment.

- * **Control box with electrical switch and safety fuse to direct foam to either side**
- * **6' power cable**
- * **15' compressor cable**

MODEL	DESCRIPTION	WEIGHT	LIST PRICE
TJEV24	6.4 Gal. poly tank, 108' poly 6 x 4 air/liquid tube covered by a flexible sheathing. 6" vertical foam drop nozzles with adjustable supports and diffuser bells.	41 lbs.	\$899
TJ15G	15 Gal. poly tank, 118' poly 6 x 4 liquid and 6 x 8 air tube covered with a soft sheathing, horizontal foam nozzles complete with new compact style angular diffuser bells and adjustable supports.	50 lbs.	\$1149
TJ1G	ATV sprayer foam marker, includes 1 Gal. tank, 2 foam outputs, 2 x 6' of tubing, remote switch control	16 lbs.	\$529

ATV - UTILITY VEHICLE **Tufline** Attachments



ATV DISC

Designed to work behind larger ATV's (450cc & up) and utility vehicles. This heavy duty ATV disc is ideal for soil preparation and ground breaking.

- * Heavy duty 2" square tube frame
- * 16" notched disc blades
- * Adjustable gang angle
- * 1" square axle shafts with sealed ball bearings
- * 7-1/2" blade spacing
- * Ratchet turnbuckle height adjustment
- * Pneumatic tires on 8" rims
- * 1-7/8" ball hitch

MODEL	DESCRIPTION	WEIGHT	LIST PRICE
ATVD7816-2	52" working width ATV disc (8) 16" disc blades	347 lbs.	\$1179
ATVD71016	64" working width ATV disc (10) 16" disc blades	498 lbs.	\$1529

ATV OFFSET DISC



For 600 cc ATV's and larger and compact tractors. Available in 42", 48" & 56" working widths. Comes with 16" notched disc blades, with 9" blade spacing on dual disc gangs which creates a more aggressive & deeper cut. Tufline has developed a unique side draft and disc pressure adjustment system that keeps the unit tracking behind power unit.

- * Heavy duty 3" square tube frame
- * Adjustable angles for each gang
- * Rated for 600cc ATV & above
- * 9" blade spacing
- * 16" notched disc blades
- * 1 7/8" ball hitch

MODEL	DESCRIPTION	# BLADES	WEIGHT	LIST PRICE
UTD91016	42" Cutting Width	10	528 lbs.	\$1839
UTD91216	48" Cutting Width	12	564 lbs.	\$1929
UTD91416	56" Cutting Width	14	605 lbs.	\$2019

ATV - UTILITY VEHICLE **Tufline** Attachments



Tufline's Flip Discs are an economical choice for use with ATV's 250 cc to 400 cc and small garden tractors.

- * Formed tube steel main frame
- * 52" cutting width
- * Eight 16" notched disc blades
- * 7-1/2" blade spacing
- * 1" square hi-strength gang axle
- * Weight tray for added weight when needed
- * Cast iron friction bearings with grease fittings offer long life
- * 1-7/8" ball hitch
- * Two 4.10 – 6 pneumatic transport tires

MODEL	DESCRIPTION	# BLADES	WEIGHT	LIST PRICE
BIO7816F	52" Flip Disc	8	245 lbs.	\$819

ATV LAND PLANE



The Monroe Tufline ATV Land Plane is designed to be pulled by larger ATV's, UTV's and small compact tractors. Available in 2 working widths, 4' and 5'. Dual angled moldboards for maximum smoothing of gravel driveways, landscaping etc. Ratchet height adjustment, replaceable cutting edges, pneumatic tires and a 1-7/8" ball hitch.

MODEL	DESCRIPTION	WEIGHT	LIST PRICE
ATVLP48	48" Working width	365 lbs.	\$1359
ATVLP60	60" Working width	415 lbs.	\$1399

ATV - UTILITY VEHICLE **Tufline** Attachments

ATV GRADER / SCRAPER BLADES

- * Angle adjustment, left or right
- * Moldboard height 15"
- * Pneumatic tires on 8" rims
- * 1-7/8" ball hitch



MODEL	DESCRIPTION	WEIGHT	LIST PRICE
ATVG48	4' (48")	215 lbs.	\$829
ATVG60	5' (60")	230 lbs.	\$869

ATV BOX SCRAPER

- * Manual lift lever for height adjustment
- * 1/8" thick plate box frame
- * Pneumatic tires on 8" rims
- * 1-7/8" ball hitch



MODEL	DESCRIPTION	WEIGHT	LIST PRICE
ATVB48	4' (48") Box blade	205 lbs.	\$829

ATV LANDSCAPE RAKE

- * Manual lift lever for height adjustment
- * 15" spring steel rake tines, mounted on 1" centers
- * Pneumatic tires on 8" rims
- * 1-7/8" ball hitch



MODEL	DESCRIPTION	WEIGHT	LIST PRICE
ATVLR48	4' (48") Landscape rake	192 lbs.	\$839
ATVLR60	5' (60") Landscape rake	203 lbs.	\$899
ATVLR72	6' (72") Landscape rake	235 lbs.	\$959

CHAIN HARROWS

Hackett Harrows

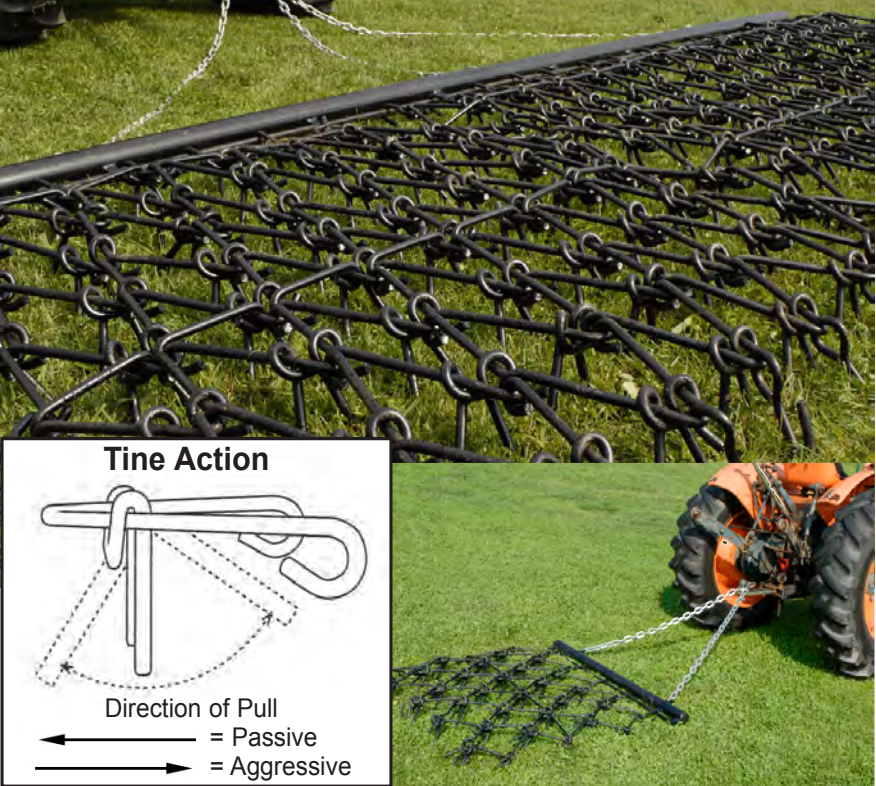

HACKETT HARROWS are designed to cover all applications from large farms to smaller hobby farms and equestrian venues. The Hackett Harrow is ideal for all types of ground work, by improving ground conditions by removing thatch, breaking up clods, working in fertilizer and breaking up and leveling soil, in established pastures, paddocks, park lands, small acreages, race tracks and horse arenas. The Hackett Harrows is manufactured in the U.K. from high quality steel, which ensures that the harrow is extremely strong with high resistance to wear. Harrows are available in 4 ft. 8 ft. 12 ft. and 16 ft. widths, x 4 ft. or 8 ft. long.

- * Tine size 1/2" x 3-1/2"
- * Sixty tines per 4 foot section
- * High quality, high carbon steel tines

- * Heat treated at optimum temperatures to ensure high resistance to wear

PULL TYPE HARROW SETS COMPLETE WITH DRAWBAR

WIDTH X LENGTH	CONTENTS	WEIGHT	LIST PRICE
4' x 4'	1-CC044 & 1-DB04U	105 lbs.	\$248
8' x 4'	2-CC044 & 1-DB08U	203 lbs.	\$447
12' x 4'	3-CC044 & 1-DB12U	301 lbs.	\$666
16' x 4'	4-CC044 & 1-DB16U	402 lbs.	\$935
4' x 8'	2-CC044 & 1-DB04U	179 lbs.	\$397
8' x 8'	4-CC044 & 1-DB08U	351 lbs.	\$745
12' x 8'	6-CC044 & 1-DB12U	523 lbs.	\$1113
16' X 8'	8-CC044 & 1-DB16U	698 lbs.	\$1531



Has a Manure Spreader to fit your Operation?



Heavy Duty Models are available in 235,270, 310, 430, 560, and 660 bushel sizes.



Hydraulic Push 425 and 550 bushel spreaders feature either vertical or horizontal beaters.



"Top Shot" Side Discharge Manure Spreaders are available in 2000, 2600, 3400 and 4200 gallon models with the Optional Digi-Star Nutrient Tracker Scale System!

MANURE SPREADER PULL TYPE



The Fimco 25 bushel ground drive manure spreader is ideal for the small farmers with cattle, horses, sheep, goats, etc. that needs to move maure and spread it on pastures. Movable apron chain with slats, moves material to rear of box where a beater with paddles spreads the manure. Can be pulled by a small lawn & garden or compact tractor or ATV / UTV.

- * 25 bushel capacity
- * Chain driven Mechanisms
- * Handy lever controls to engage apron chain & beater
- * Corrosion resistant bed floor
- * Overall width 48" x length 9' 9" x height 31"
- * Box dimension 72" L x 28" W x 18-1/2" H
- * Ground drive tire size 6.00 x 12 with Ag. tread
- * Includes tongue jack

MODEL	DESCRIPTION	WEIGHT	PRICE
MS25BU	Manure spreader ground drive	464 lbs.	\$2939



AMAZONE

AMAZONE's ZG-B range of bulk fertilizer spreaders represents a high output range of machines for the efficient and ecological application of mineral fertilizers and earth moist fertilizers. All models have certain features in common: they offer the best possible spreading accuracy, maximum reliability, and are easy and convenient to operate, which makes them ideal for use by large farms, agricultural contractors, or in farming cooperatives. Different specification variants and a comprehensive range of accessories make AMAZONE fertilizer spreaders the obvious first choice for any business.



ZG-B Special

Belt floor and spreader unit drive
via PTO shaft
Fertiliser metering via belt floor
Hopper capacity 5,500 / 8,200 l
Working widths 10 - 36 m

ZG-B Super

Belt floor drive via ground wheel
(forward-speed related rate control)
Fertiliser metering via belt floor
Hopper capacity 5,500 / 8,200 l
Working widths 10 - 36 m



ZG-B Drive

Electro-hydraulic belt floor drive
(forward-speed related rate control)
Fertiliser metering via belt floor
Hopper capacity 5,500 / 8,200 l
Working widths 10 - 36 m



AMAZONE

ROCK RAKES



PWD10



WD6

Houle Fabrication offers 4 models of rock rakes, two 3 Pt. hitch and three pull types, 540 PTO RPM, for windrowing rocks for easier pickup. The most efficient rock rake on the market because of the many features that make them easy to use and to move. Made in CANADA.

MODEL	DESCRIPTION	WEIGHT	LIST PRICE
WD6	5' 2" working width, Cat II, 3 Pt. hitch 540 RPM PTO, slip clutch PTO with 2-16.5" x 6.5" pneumatic tires. Replaceable and reversible teeth. Sealed transfer case. Recommended HP 40-60 HP	1150 lbs	\$8599
WD10B	10' working width, 3 Pt. Cat. II, two 18.5 x 8.5 tires which swivel 360°, maintains balance, replaceable & reversible teeth, sealed Transfer case for longer lasting #100 drive chain, Slip clutch PTO. Recommended HP 65-125 HP, recommended speed 4-6 kmh.	1850 lbs.	\$10,999
PWD10	10' working width, pull type with 11L x 15 transport tires, replaceable and reversible teeth, adjustable flotation system provides protection against breakage & obstacles. Includes lift hydraulic cylinder & hoses. #100 Drive chain. Slip clutch PTO. Recommended HP 50-125 HP. Recommended speed 4-6 kmh.	2400 lbs.	\$13,399
SRR15	15' working width, pull type with 11L x 15 transport tires, comes with Manual transport kit. Replaceable and reversible teeth, adjustable flotation system provides protection against breakage & obstacles. Includes lift hydraulic cylinder & hoses. Slip clutch PTO, #100 drive chain. Recommended HP 65 + HP, recommended speed 4-6 kmh.	3600 lbs.	\$19,699
SWD15	15' working width, pull type with 11L x 15 transport tires, comes with Hydraulic transport kit. Replaceable and reversible teeth, adjustable flotation system provides protection against breakage & obstacles. Includes lift & transport hydraulic cylinders & hoses. Slip clutch PTO, #100 drive chain. Recommended HP 65 + HP, recommended speed 4-6 kmh.	4700 lbs	\$21,299

15 ft. hydraulic driven models now available in SRR15 and SWD15 models.

F.O.B. St. Germain PQ

TREE SAW



TS100 Model Shown



TSG201 Model Shown

The BROWN TREESAWS are designed to be rugged machines that can handle selective clearing of wood lots, fence rows, food plots, ATV/bike trails etc. the heavy construction is tough enough to cut heavy brush and trees up to 8" in diameter. The balanced blade keeps vibration to a minimum. The TS100 comes with a rigid brush bar for controlling brush and trees as you cut them. The TSG200 comes with a hydraulic grapple for moving brush and cut trees after cutting. Both units include a brush guard to protect operator.

- * **Minimum HP required 35 HP**
- * **Cat. I 3 Pt. Hitch**
- * **Height of cut: ground level**
- * **All welded construction**
- * **Gear Box Ratio 1: 1.5**
- * **540 RPM PTO**
- * **30" Blade with replaceable carbide teeth**

MODEL	DESCRIPTION	WEIGHT	LIST PRICE
TS100	TREESAW with brush guard	850 lbs.	\$5399
TSG201	TREESAW with hydraulic grapple & brush guard (includes hydraulic hose)	1050 lbs.	\$6539

TREE CLIPPERS

Tractor Front End Loaders & Skid Steers



The Tree Clipper offers a time saving way to trim & clear tree's & brush that is much faster & easier than using a chainsaw. The Tree Clipper is ideal for eliminating low hanging branches from fence lines, while reducing damage to tractor & combine cabs. The Tree Clipper eliminates the unsafe practice of trimming limbs with a chain saw from a loader bucket or ladder.

- * Cuts limbs & trees up to 8" dia.
- * Cuts flush to the ground
- * Heavy duty 5" x 8" hydraulic cylinder with 2" rod & 1-1/4" pins for positive cutting action
- * Hardened pivot bushings
- * Self-centering 3/4" T-1 steel blades
- * Power-tilt to rotate head assembly for best cutting angle
- * Allows trimming of limbs 12-16' high (depending on tractor, loader or skid steer)
- * For tractor loaders - loader mounting brackets extra. Pin type or quick attach available. (Requires extra hose to reach rear hydraulic remotes)
- * For skid steers - comes standard with universal quick-attach brackets
- * For skid steers - Includes electric solenoid valve & hose kit (less couplers)

MODEL	DESCRIPTION	WEIGHT	LIST PRICE
TC8FL	For tractor front end loaders	710 lbs.	\$5679
TC8SS	For skid steers	723 lbs.	\$7029

TREE SHEARS



TS08



TS16
Shown with optional
brush guard

F.O.B. St. German, PQ

TREE SHEARS



S. Houle Fabrication offers two tree shears, a 8" and a 16" cutting capabilities. Available in tractor loader mount or skid steer mount.

8" TREE SHEAR	
TS08 LOADER MOUNT	TS08SS SKID STEER MOUNT
YOUR CHOICE LIST PRICE - \$6649	
<ul style="list-style-type: none"> * Cuts up to 8" capacity * Designed to trim and cut trees and limbs in tight spaces and near fence lines. * The cylinder's thrust provides each blade with 60,000 PSI * For tractors, skid steers and tele-handlers minimum 60 HP with hydraulic flow 75-95 LM/14-19GPM @ 2700-3000 PSI. * 6" x 5" hydraulic cylinder for scissor action blades * 3" x 11' hydraulic cylinder for rotation cylinder * Cutter head rotates 110 degrees * Blades are made of RT-400 Steel * A single electro-hydraulic valve allows you to switch from one hydraulic cylinder to the other * Tractor loader mount requires optional loader mounting brackets., extra. * Skid steer mount comes with universal skid steer mounting bracket * Weight 987 lbs. (448kg) 	
16" TREE SHEAR	
TS16 TRACTOR LOADER MOUNT	TS16SS SKID STEER MOUNT
YOUR CHOICE LIST PRICE - \$9349	
<ul style="list-style-type: none"> * Cuts up to 16" Capacity * Cutting power up to 85,000 PSI * Requires a minimum of 75 HP tractor, skid steer or tele-handler with minimum hydraulic flow 75-95 LM (20-25 GPM) @ 2700 – 3000 PSI * RT-400 Steel frame and a blade with an RT-400 steel cutting edge that is also reinforced to eliminate distortion * Single blade eliminates center cut splinters * Blade moves from left to right for better operator visibility * Concave jaw design * 3" x 8" hydraulic tilt cylinder rotates cutter head 110 degrees * Massive 3" blade pivot pin provides unmatched rotational strength. * All pivot points are greaseable. * A single electro-hydraulic valve allows you to switch from one cylinder to the other * Tractor loader mount requires optional loader mounting brackets., extra. * Skid steer mount comes with universal skid steer mounting bracket * Weight 1550 lbs. (705kg) 	

OPTIONS:

DESCRIPTION

LIST PRICE

CA011604E02
31031

Brush Guard for TS16
High Flow Solenoid 3500 + PSI

\$599
\$439

F.O.B. St. Germain, PQ

LOGGING WINCHES

Fransgård



The **FRANSGÅRD** winch was designed for log skidding in wood lot applications. They are available in 5 models according to pulling capacity. They range from 6600 lbs to 14,300 lbs pulling capability. The overall dimensions of the winch are specifically designed to enable easier access in narrow passages. The winch can also be used for log "dozing" and land leveling making the Fransgård winch a versatile piece of equipment.

- * Winches are available in 5 models for 3 Pt. hitch tractors.
- * Standard with slip clutch protection
- * Standard cable with one hook included
- * Cable is pre-installed on wire drum
- * HP Requirements: 25-80
- * Protective screen guard included
- * Extra supports on the top pulley provide additional resistance when pulling heavier logs
- * A cable drum tension bracket prevents unspooling of the cable when pulling the cable out

MODEL	PULL CAP.	WEIGHT	TRACTOR HP REQ'D	CABLE LENGTH	CABLE DIA.	LIST PRICE
V3004	6600 lbs	385 lbs.	25	133'	5/16"	\$3599
V3507	7700 lbs	408 lbs.	25	133'	5/16"	\$4099
V4000	8800 lbs	550 lbs.	40	167'	3/8"	\$4899
V5000	11,000 lbs	667 lbs.	40	167'	3/8"	\$5999
V6500	14,300 lbs	880 lbs.	80	167'	7/16"	\$6999

CAUTION: Timber winches are mounted very close to the tractor for maximum stability, therefore PTO length is critical. Stock length shaft supplied may require shortening to suit tractor. Operator should ensure that the PTO is never operated at over a 30 degree angle. Three point hitch linkage must have lower setting adjusted so winch does not dig into soft ground pulling the or breaking the PTO shaft. There is no warranty on PTO shafts and knuckles broken or bent under the circumstances listed above. Never transport logs hooked to top of winch by cable, always use chains hooked to transport bar which gives a lower center of gravity.

NOTE : Please review owners manual as there are specific operating and maintenance instructions - cables are considered a wearing part and are not covered by warranty.

Not available in Quebec

LOGGING WINCH Accessories

Fransgård



1582



1562



1525/1546/1556



1586/1588



1584



1595/1596

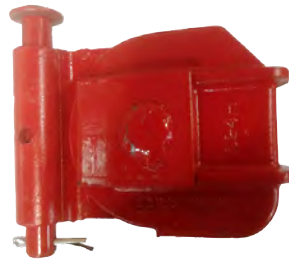

1593

MODEL	DESCRIPTION	LIST PRICE
1562	End hook for cable	\$17
1582	Choker/Slider	\$32
1584	Choker chain 7' silver (for use w/V3004 & V3507. Work load 2200lbs/1000kg)	\$52
1586	Choker chain heavy duty 7' red (for use with V4000 & V6500 Work load 6615 lbs/3000kg)	\$90
1588	Choker chain heavy duty 10' red (for use with V4000 & V6500 Work load 6615 lbs/3000kg)	\$115
1593	Middle Pulley for V3004 and V3507	\$135
1595	Distance Pulley - 4000 kg / 8800 lbs.	\$439
1596	Distance Pulley - 13000 kg / 28600 lbs.	\$1099

LOG SPLITTER

Engine Driven
Towable



TL23357



TL2HV25



TL23353

LOG SPLITTER

Engine Driven

Towable



The new TERRALINE of engine driven, towable log splitters include three models, 22 ton, 25 ton, vertical and horizontal split, and a 25 ton dual action horizontal splitter. All units come with Hi-speed (45 MPH) tires, 2" ball coupler.

MODEL	DESCRIPTION	WEIGHT	LIST PRICE
TL23357	22 Ton, 208cc LCT Engine VERTICAL OR HORIZONTAL SPLITTER 11 GPM 2 Stage Gear Pump, 4" X 23" Hydraulic Cylinder Oil Capacity 2.64 Gallon. Maximum Splitting Length 24". Maximum Splitting Diameter 14" 7" Hardened Steel Wedge, Auto Return Hydraulic Valve 16" x 6.5" Pneumatic Tires, (NO Fenders)	343 lbs	\$1495
TL2HV25	25 Ton, 208cc LCT Engine VERTICAL OR HORIZONTAL SPLITTER 11 GPM 2 Stage Gear Pump, 4.5" X 24" Hydraulic Cylinder Oil Capacity 6.5 Gallon. Max Splitting Length 26" 8" Hardened Steel Wedge, Auto Return Hydraulic Valve 16" x 6.5" Pneumatic Tires	485 lbs	\$1599
TL23353	25 Ton, 208cc LCT Engine DUAL ACTION HORIZONTAL SPLITTER 11 GPM 2 Stage Gear Pump, 4.5" X 24" Hydraulic Cylinder Oil Capacity 2.64 Gallon. Max Splitting Length 24". Max. Dia. 16" Splitting Force forward: 25 ton max Splitting Force return: 18.5 ton Splitting Speed forward: 9 sec Splitting Speed return: 7 sec 7.5" Hardened Steel Wedge, Auto Return Hydraulic Valve 16" x 6.5" Pneumatic Tires	430 lbs	\$1729

OPTIONS:

MODEL	DESCRIPTION	LIST PRICE
TL4XW-ES22	4-way cross wedge for TL23357	\$75
TL4XW-DS25	4-way cross wedge for TL2HV25	\$75

LOG SPLITTER

3 Pt. Hitch



The new TERRALINE of log splitters include this 3 point hitch model. Attaches to Cat. I 3 Pt. Hitch tractors, horizontal Split, 14 ton capacity (depending on hydraulic output of tractor). Optional stand and 4 way cross wedge is available. Does not include hydraulic hoses (2) or hydraulic coupler plugs to tractor.

- * Cat. I 3 Pt. Hitch
- * 14 ton capacity
- * Recommended 11 GPM from tractor
- * Splits in horizontal position
- * Maximum log length 24"
- * Cylinder size 4" x 24"
- * Pressure relief setting 2500 PSI
- * 7.87" Hardened steel wedge

MODEL	DESCRIPTION	WEIGHT	LIST PRICE
TL23303	3 Pt. Hitch Cat. I 14 ton capacity	251 lbs.	\$875

OPTIONS:

MODEL	DESCRIPTION	LIST PRICE
TL4XW-TP14	4-way cross wedge	\$75

STUMP GRINDERS

3 Pt. Hitch



SureFoot Stabilizer Bar

This **WORKSAVER** economical and efficient PTO powered stump grinder makes stump removal fast & easy. The operator easily controls the stump grinder from the comfort of their tractor seat.

- * **Maneuverable - goes anywhere a tractor can.**
- * **Cutting wheel design provides a smoother cutting action.**
- * **Durable carbide -tipped cutting teeth are economical and easy to replace.**
- * **SUREFOOT stabilizer bar provides solid footing during operation.**
- * **Rubber deflector helps control chips during grinding.**
- * **Hardened bushings used in major pivot points for increased reliability.**

MODEL	SG26 (3 Pt)	SG36 (3 Pt)
LIST PRICE	\$6159	\$7089
Hitch	Cat. 1	Cat. 1 and 2
Overall Length	75"	80"
PTO Driveline	Series 5	Series 6
Driveline Protection	Slip Clutch	Slip Clutch
Gearbox Rating	60 HP	100 HP
Cutting Wheel Thickness	3/4"	3/4"
Cutting Wheel Diameter	26"	36"
# Of teeth	30	39
Cutting Ht Above Ground	18"	18"
Cutting Ht Below Ground	10"	10"
Max. Cut Depth Per Pass	5"	8"
Max. horizontal cut	28"	33"
Swing Arc	45°	45°
HP Requirement	22-50	45-100
Weight	660 lbs.	880 lbs.

OPTIONS:

MODEL	DESCRIPTION	LIST PRICE
811600	Box of 25 replacement carbide teeth with bolts and washers	\$283

Weights indicated are base machine weight, not shipping weight

6" CHIPPER



The Bushmaster PTO driven chipper saves time and labour by reducing humus material to a valuable mulch. Ideal for nurseries, contractors, small municipalities and golf courses. The Bushmaster PTO driven chipper comes complete with:

- * HP Requirements: 30-50, 540 RPM
- * Variable speed power feed 70 or 45 FPM
- * Continuous chipping capacity of up to 6"
- * Power feed on/off control bar
- * Cat. I 3 Pt. hitch
- * Drum style chipping wheel gives sure handled feeding
- * Easy access to belts and chipper knives
- * Built in high volume blower with optional 15" extension pipe
- * Heavy duty shielded PTO shaft (1-3/8" ASAE Cat. 4)

MODEL	CHIPPING CAPACITY	# KNIVES	WEIGHT	LIST PRICE
BM6-800	6"	2	900 lbs.	\$8139

OPTIONS:

MODEL	DESCRIPTION	LIST PRICE
BM6-000	15" Blower pipe extension	\$159

FORESTRY GRAPPLE 3 PT

Fransgård

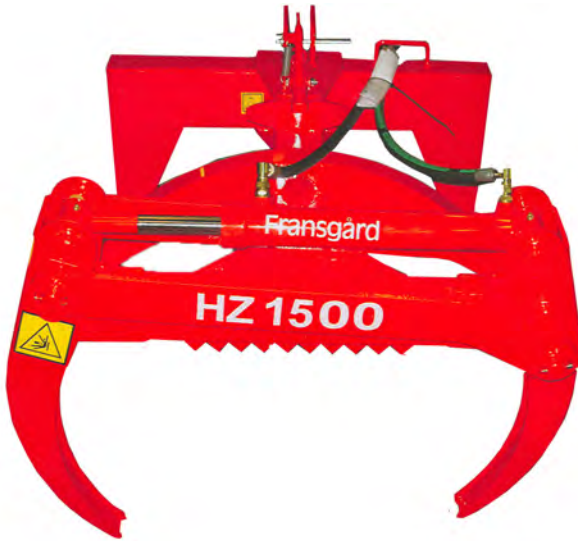

The **FRANSGÅRD** Forestry Grapple is unique 3 Pt. hitch attachment. The HZ1500 is smaller for 20-50 HP tractors. The HZ1500 comes with manual swing. The oblong top link hole in the unit enables the grapple to "float" in rugged terrain.

- * 1 set of hyd. remotes req'd
- * Grapple opening 60"
- * HP req'd 20-50
- * Bronze bushing in all pivot points
- * Manual swing
- * Grapple power 5520 lbs at 1700 PSI

MODEL	DESCRIPTION	WEIGHT	LIST PRICE
HZ1500	Manual Swing	295 lbs.	\$2999

GRAPPLE RAKES

Compact Tractors up to 40 HP



WORKSAVER grapple rakes for skid steer and tractor front loaders are ideal for loading logs, picking rocks, and orchard prunings. Can be used for raking and piling brush and other hard to handle materials. Skid steer models use “Universal attaching” system for quick convenient method of hook-up. Tractor front loader mounting brackets extra. Pin type or quick attach brackets available.

- * **Single grapple**
- * **Single cylinder controls upper grapple**
- * **Optional interfacing quick-attach bracket available to fit most John Deere, AGCO, Kubota, CNH, and other brands of loaders.**
- * **The FLGR-4062S is used on OEM loaders that utilize the skid steer quick-attach system**

MODEL	APPLICATION	WIDTH	WEIGHT	LIST PRICE
FLGR4062	Front Loader	60"	359 lbs.	\$1989
FLGR4062S	Front Loader with skid steer quick-attach system	60"	355 lbs.	\$2129
NOT FOR USE ON SKID STEER LOADERS				

GRAPPLE RAKES

Tractors / Skid Steer



WORKSAVER grapple rakes for skid steer and tractor front loaders are ideal for loading logs, picking rocks, and orchard prunings. Can be used for raking and piling brush and other hard to handle materials. The split top design provided dual upper grapples for picking up brush and other debris while leaving the dirt behind. Skid steer models use “Universal attaching” system for quick convenient method of hook-up. Tractor front loader mounting brackets extra. Pin type or quick attach brackets available.

- * **Two working widths 62” and 77” with 4 grapple tines**
- * **Tine spacing 15” center to center**
- * **Grapple opening 50”**
- * **Grapple depth 25”**
- * **Reinforced tubes welded between lower tines for added strength**
- * **Includes hydraulic cylinders, less hoses**

MODEL	APPLICATION	WIDTH	WEIGHT	LIST PRICE
FLGR262	Front Loader	62”	786 lbs.	\$3469
FLGR277	Front Loader	77”	966 lbs.	\$3975
SSGR262	Skid Steer	62”	784 lbs.	\$3729
SSGR277	Skid Steer	77”	964 lbs.	\$4199

OPTIONS:

MODEL	DESCRIPTION	LIST PRICE
811395	Parking Stand Kit, 26 lbs Allows upright storage and easy hook up on hard surfaces	\$209

ROCK BUCKET

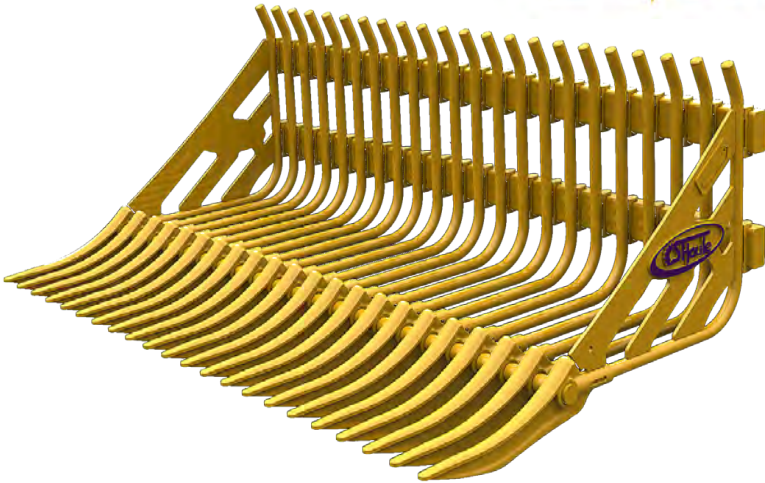

HOULE Rock buckets are a Canadian made product and can be used for digging, rock picking, the removal of asphalt, brush, tree stumps and any large debris that needs to be removed and the soil left behind. Houle is the only company to offer a lifetime warranty for broken tines.

- * Each tooth made from spring steel.
- * Priced less mounting brackets

MODEL	WORKING WIDTH	LENGTH	HEIGHT	# OF TEETH	WEIGHT (LBS.)	LIST PRICE
STANDARD ROCK BUCKET 1 1/4" TOOTH DIA. X 2 1/2" SPACING TENSILE STRENGTH - 112,500 Lbs.						
B6	72"	42"	24"	20	720	\$2550
B7	84"	42"	24"	23	825	\$2795
B8	96"	42"	24"	26	925	\$2995

HEAVY DUTY ROCK BUCKETS 1 1/2" TOOTH DIA. X 3" SPACING TENSILE STRENGTH - 135,000 Lbs.						
HB6	72"	40"	24"	16	750	\$2835
HB7	84"	40"	24"	19	880	\$3065
HB8	96"	40"	24"	22	1015	\$3290
HB9	108"	40"	24"	25	1105	\$3520

SUPER HEAVY DUTY ROCK BUCKETS 1 3/4" TOOTH DIA. X 4" SPACING TENSILE STRENGTH - 157,500 Lbs.						
SHB8	96"	46"	24"	17	2075	\$6690
SHB9	108"	46"	24"	19	2205	\$7000

SHB requires special loader mounting brackets. **Price on Request**

Call your local dealer for availability and pricing on heavy duty U-Bolt type quick attach brackets for your loader

GRAPPLES FOR ROCK BUCKETS

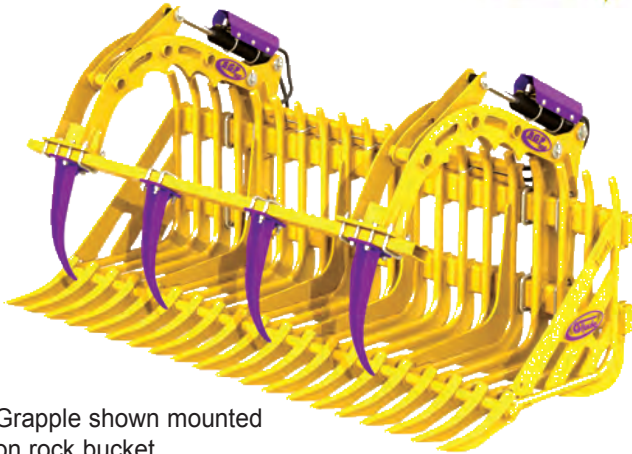

Grapple shown mounted on rock bucket

Houle provides two models of Grapple attachments for their **rock buckets** depending on the model. Units bolt on to buckets, and include two 2-1/2" x 18" hydraulic cylinders, (less hydraulic hoses to tractor), & four replaceable hardened steel teeth. Units are easily detached from bucket when not required.

MODEL	DESCRIPTION	WEIGHT	LIST PRICE
GP10	Fits 6' to 9' B & HB Rock Buckets	625 lbs.	\$2099
SGP10	Fits 7' to 9' SHB Rock Buckets	700 lbs.	\$3005



SSQA150



A0600 Alo Loaders



U-BOLT ON QUICK ATTACH BRACKETS

S. Houle Fabrication U-Bolt-On quick attach brackets are manufactured extra heavy duty to withstand the punishment of digging and picking stones and rocks. Designed and built to allow bucket more roll back.

MODEL	DESCRIPTION	WEIGHT	LIST PRICE
UA100	U-Bolt-On pin type loader brackets (pair)	70 lbs.	\$309
SSQA150	U-Bolt-On universal skid steer quick attach bracket	105 lbs.	\$459
AO600	U-Bolt-On quick attach brackets for ALO loaders	105 lbs.	\$459

Also available many more brackets to fit Allied (Farm King), Alo, Case IH, JD, FNH, Cat, Kubota, MF. etc. Check with your local dealer for the availability of brackets for your loader.

GRAPPLE BUCKET LOW PROFILE SKID STEER



Model LPSB



Model LPTG

Worksaver's NEW Low Profile Grapple Buckets come in two different styles, Tine Bottom and Solid Bottom. Available in four models, all with a split grapple assembly with 2 hydraulic cylinders with cylinder guards to protect cylinders and hoses. These NEW Grapple Buckets are manufactured to attach to any skid steer with the "universal" skid steer quick attach mounting system. Comes with hydraulic hoses and "connect under pressure" flat faced couplers.

- * 72" & 84" overall width
- * Split grapple assembly
- * Tine grapple has 7 1/2" spacing
- * Scrap bucket cutting edge is pre-drilled to accept optional replaceable bevelled cutting edge
- * Complete with "connect under pressure" flat faced couplers
- * Two 2"x10" Hyd cylinders with cylinder guard protection
- * Universal skid steer quick attach mounting bracket

MODEL	DESCRIPTION	WEIGHT (LBS.)	LIST PRICE
LPTG72	72" Low profile tine grapple bucket	820 lbs.	\$3779
LPTG84	84" Low profile tine grapple bucket	898 lbs.	\$4059
LPSB72	72" Low profile scrap grapple bucket	760 lbs.	\$3819
LPSB84	84" Low profile scrap grapple bucket	855 lbs.	\$4289

OPTIONS: FOR LPSB72 OR LPSB84 SCRAP BUCKET

MODEL	DESCRIPTION	LIST PRICE
811790	3/4" x 8" x 72" reversible cutting edge & hardware	\$459
811870	3/4" x 8" x 84" reversible cutting edge & hardware	\$529

MANURE FORKS



M/SG-72S



M/S-60S

The WorkSaver Manure Fork was designed for picking up manure, matted straw or other loose materials. Excellent for handling silage, units with upper grapple helps secure load during transport improving productivity. All units have forged cranked tines for extended service life. Units with upper grapple and skid steer mount are supplied with hydraulic hoses and connect under pressure couplers for ease of installation. Models with upper grapple have greasable pivot points for long life and cylinder pivot points utilize replaceable harden bushing to reduce wear.

- * Available in 60" & 72" widths
- * Available with or without upper grapple
- * Overall depth 31" / 787mm
- * Overall height 21.5" / 546mm
- * Useable tine length 27" / 686mm
- * Upper grapple width 34" / 864mm
- * Tine spacing 7.5" / 190mm
- * Number of tines 60" - 8, 72" - 10

Units come with Universal Skid Steer quick attach plate. Includes hydraulic hoses and flat face couplers.

MODEL	DESCRIPTION	WEIGHT	LIST PRICE
MS60S	Manure fork 60" wide	225 lbs.	\$1079
MSG60S	Manure fork 60" wide with upper grapple	405 lbs.	\$2539
MS72S	Manure fork 72" wide	270 lbs.	\$1169
MSG72S	Manure fork 72" wide with upper grapple	450 lbs.	\$2769

Units require Optional Bolt-on Quick Attach Brackets. To be ordered separately. Units with upper grapple come LESS hydraulic hoses & couplers.

MODEL	DESCRIPTION	WEIGHT	LIST PRICE
MS60U	Manure fork 60" wide	225 lbs.	\$1079
MSG60U	Manure fork 60" wide with upper grapple	375 lbs.	\$2199
MS72U	Manure fork 72" wide	270 lbs.	\$1169
MSG72U	Manure fork 72" wide with upper grapple	450 lbs.	\$2449

PALLET FORKS



- * Clamp-On to material loader Bucket
- * Available in three sizes
- * No tools required to install

MODEL	DESCRIPTION	WEIGHT	PRICE
BF1000	1000 lb capacity, 35" usable length, pair.	78 lbs.	\$429
BF2000	2000 lb capacity, 42" usable length, pair.	102 lbs.	\$485
BF4000	4000 lb capacity, 42" usable length, pair.	168 lbs.	\$789



SSPF448



PF448

- * 1-1/4" x 4" solid forks with spring loaded toggle latch for positioning
- * Skid steer mount units have step through design

MODEL	DESCRIPTION	WEIGHT	LIST PRICE
SSPF442	Pallet forks 4000 lb. rated, 42" long to fit skid steer or tractor loaders with universal skid steer attach system	345 lbs.	\$1099
SSPF448	Pallet forks 4000 lb. rated, 48" long to fit skid steer or tractor loaders with universal skid steer attach system	359 lbs.	\$1099
PF448	Pallet forks 4000 lb. rated, 48" long to fit tractor loaders. Designed to mount to tractor loaders with centre to centre between arms up to 50" Optional interfacing quick attach brackets extra	438 lbs.	\$1099

Pallet forks available for John Deere 400/500 series loaders and loaders with GLOBAL / EURO attaching system

COMPACT PALLET FORKS

For 40 HP Tractors / Loaders



These newly designed compact pallet forks from WorkSaver incorporates many of the same durability features found in our larger units. These models utilize Class I forks (1" x 4" x 42") rated at 2,000 lbs. for the pair providing optimal lifting capacity. Spacing adjustment is easy with spring loaded latches allowing the operator to move the forks along the notched rail.

- * **Class I solid steel alloy forks**
- * **Forks are 1" x 4" x 42" rated @ 2000 lbs. / pair**
- * **Rail style forks with spring loaded latches**
- * **3 models available for tractors with loaders up to 40 HP**

MODEL	DESCRIPTION	WEIGHT	LIST PRICE
SSPF242	Pallet forks 2000 lb. rated to fit loaders with universal skid steer attaching systems	290 lbs.	\$839
FLPF2000	Pallet forks 2000 lb. rated to fit any compact tractor loader under 40HP accepting quick attach system Brackets extra (sold separately)	270 lbs.	\$889
JDPF2000	Pallet forks 2000 lb. rated to fit John Deere 200 / 300 Series with JD quick attach system	280 lbs.	\$939

FINGER WHEEL RAKES

3 Pt. Single Side

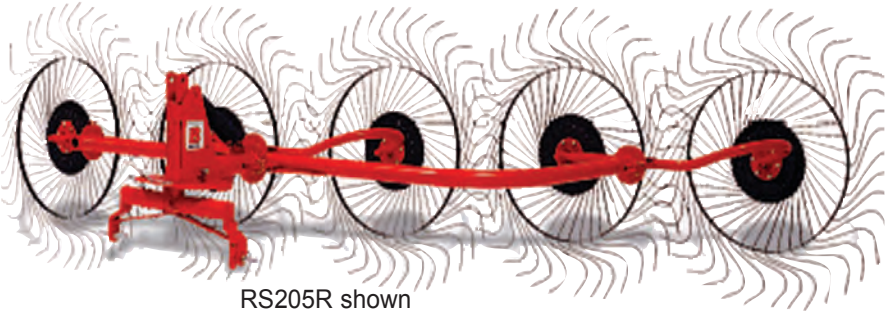

RS205R shown



RS202R shown

For tractors from 30 HP engine and up. Category 1 or 2, 3 Pt. hitch. Finger rake wheels are mounted on molded steel hubs with tapered bearings. Lifts hay gently, and evenly from undulating terrain. May also be used for raking, turning or spreading swaths. Its fast working speed makes it possible to cover a large acreage quickly. Having no gears, chains or other drive components to wear out, the finger wheel rake is truly a low maintenance tool.

- * **HP Requirements: 30-80**
- * **Cat. 1 3 Pt. hitch**
- * **Molded steel hubs with greasable tapered bearings**
- * **May also be used for raking, turning or spreading swaths**
- * **Lifts hay gently, even from undulating terrain**

MODEL	# WHEELS	MAXIMUM WORKING WIDTH	WEIGHT	LIST PRICE
RS202R	2	4' 3"	194 lbs.	\$719
RS203R	3	6' 5"	291 lbs.	\$1059
RS204R	4	8' 6"	388 lbs.	\$1409
RS205R	5	11'	495 lbs.	\$1729
RS206R	6	12' 9"	602 lbs.	\$2059

HAY HANDLING ATTACHMENTS FOR JOHN DEERE LOADERS & ALO GLOBAL STYLE QUICK ATTACH LOADERS



JDBS423 &
JDBS623



JDBS412 & JDBS612



GLB3000



GLB2200



GLB340

HAY HANDLING ATTACHMENTS FOR JOHN DEERE LOADERS & ALO GLOBAL STYLE QUICK ATTACH LOADERS



**For John Deere loaders
300,300CX,400X,410,420,430,440,460,520,521,540,541**

MODEL	DESCRIPTION	WEIGHT	LIST PRICE
JDBS412	2200 lb. Single Loader Bale Spear 42" tapered forged spear with two 1" x 8-1/2" balance spikes	121 lbs.	\$589
JDBS423	3000 lb. Dual Loader Bale Spear Two 42" forged tapered spears.	156 lbs.	\$749

**For John Deere loaders
620,640,720,721,725,726,740,741**

MODEL	DESCRIPTION	WEIGHT	LIST PRICE
JDBS612	2200 lb. Single Loader Bale Spear 42" tapered forged spear with two 1" x 8-1/2" balance spikes	176 lbs.	\$799
JDBS623	3000 lb. Dual Loader Bale Spear Two 42" forged tapered spears, spaced 30" apart	196 lbs.	\$919

For Global/Euro Quick Attach Loaders

MODEL	DESCRIPTION	WEIGHT	LIST PRICE
GLB2200	2200 lb. Single Loader Bale Spear 42" tapered forged spear with two 1" x 8-1/2" balance spikes	114 lbs.	\$539
GLB3000	3000 lb. Dual Loader Bale Spear Two 42" forged tapered spears, spaced 30" apart	128 lbs.	\$649
GLB340	4000 lb. rated Three Spear 42" useable spear length for large size square bales	195 lbs.	\$849

OPTION

831095	Bolt-on Upright kit for handling two square bales.	32 lbs	\$139
--------	---	--------	-------

HAY HANDLING ATTACHMENTS

Bucket Mount



BBSF20



CBSF2000



CBSF3028

MODEL	DESCRIPTION	WEIGHT	LIST PRICE
BBSF20	2,000 Lb. Bolt-on Bucket Bale Spear Single tapered forged tine for use with tight center bales	68 lbs.	\$345
CBSF2000	2,000 Lb. Clamp-on Bucket Bale Spear Chain and turnbuckle system. 42" long Single tapered forged tine for use with tight center bales.	79 lbs.	\$399
CBSF2028	3000 Lb. Clamp-on bucket Uses chain and turnbuckle system. Two 42" tapered forged spears	102 lbs.	\$625
CBSF3028	4000 Lb. Clamp-on bucket THREE bales spear. Uses 2 chains & turnbuckle system. Three 42" tapered forged spears	185 lbs.	\$909

HAY HANDLING ATTACHMENTS

Front Loader or Skid Steer



MODEL	DESCRIPTION	WEIGHT	LIST PRICE
LSFB22	2,200 Lb. Bale Spear. For pin-type loaders only Single 42" long tapered forged tine for use with tight center bales. Not Quick Attach Adaptable	150 lbs.	\$459
LSFB28	3,000 Lb. Bale Spear. For pin-type loaders only. Two 42" long tapered forged tines for use with tight center bales. Not Quick Attach Adaptable	165 lbs.	\$569
FLBS2200	2200 lb. rated Single Loader Bale Spear Single 42" tapered forged spear. Requires Optional Interfacing. Quick Attach Brackets (not included)	121 lbs.	\$489
FLBS3000	3000 lb. rated Dual Loader Bale Spear Two 42" forged tapered Spears. Requires Optional Interfacing Quick Attach Brackets (not included)	136 Lbs.	\$569

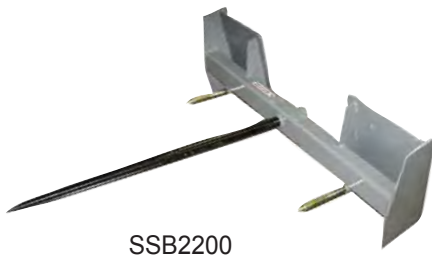

SSB2200

MODEL	DESCRIPTION	WEIGHT	LIST PRICE
SSB2200	2,200 Lb. Forged Bale Spear All welded frame. Single 42" long tapered forged tine for use with tight center bales. Comes with universal skid steer quick attach mounting bracket.	134 lbs.	\$565

HAY HANDLING ATTACHMENTS

3 Pt. Hitch Only



BSF1523



BSFA20



HHU2045

BALE SPEAR

MODEL	DESCRIPTION	WEIGHT	LIST PRICE
BSF1523	1,800 Lb. 3 pt. Bale Spear Cat. 1 & 2. Single spear is 44" tapered forged spear for excellent penetration into the bale, w/welded balance spears.	60 lbs.	\$259
BSFA20	2,000 Lb. 3 pt. Bale Spear Cat. 1 & 2. Single spear is 44" tapered forged spear, w/welded balance spears.	79 lbs.	\$459

HAY HANDLER / BALE UNROLLER

MODEL	DESCRIPTION	WEIGHT	LIST PRICE
HHU2045	2,000 Lb. 3 Pt. Hay Handler/Unroller 4' to 5' width & up to 6' diameter bales. Cat. 1, 2 & 3. 3 Narrow Quick Hitch. Use 2.5" x 8" Hydraulic Cylinder (Not included.)	310 lbs.	\$1099

HAY HANDLING ATTACHMENTS

Bale Huggers Front Loader Mount



UBH2000



UBH2072

MODEL	DESCRIPTION	WEIGHT	LIST PRICE
UBH2000	2,000 Lb. Bale Hugger For 4' to 6' wrapped or unwrapped bales. Hydraulic cylinder included. Loader mounting brackets extra. Pin type or quick attach available.	435 lbs.	\$2139
UBH2072	2,200 Lb. Bale Handler For 4' to 6' wrapped or unwrapped bales. Hydraulic cylinder included. Loader mounting brackets extra. Pin type or quick attach available.	529 lbs.	\$2399

HAY HANDLING

Bale Huggers Skid Steer Mount



SSBH2072

MODEL	DESCRIPTION	WEIGHT	LIST PRICE
SSBH2072	2,200 Lb. Bale Handler For 4' to 6' wrapped or unwrapped bales. Hydraulic cylinder included. Comes with universal skid steer quick attach mounting bracket.	470 lbs.	\$2755

HAY HANDLING ATTACHMENTS RW Spin Off



Designed as an efficient hay management tool for moving and feeding round bales. The Spin Off hydraulically rotates the bale, unwinding the hay into a windrow.

- * Eliminates wasted hay, only unroll what cattle will clean up in one hour
- * Easy operation from cab of tractor or skid steer
- * 3 Pt. hitch, front tractor loader or skid steer mount available
- * Hydraulically driven for better operator control
- * Rotates in both directions for easy feeding
- * Cushion valve in the motor provides protection for hydraulic components
- * 44" forged tapered spear
- * GPM Requirement 8-10 GPM. Min. 1500 PSI
- * 3 pt. & skid steer models include hyd. hoses, tractor loader mount, less hyd. hoses. Less hyd. couplers

MODEL	DESCRIPTION	WEIGHT	LIST PRICE
FSO906	3 Pt Hitch Cat II/III Can be converted to Cat 1 with bushings & Cat 1 pins, (not included). Includes 2 hyd hoses, less couplers	250 lbs.	\$2339
FLSO907	Front tractor loader mount Less hyd hoses, less loader mounting brackets Optional brackets for most loader makes available	370 lbs.	\$2575
SSSO908	Skid Steer Mount Includes "Universal" skid steer quick attach bracket. Includes 2 hyd hoses (less couplers)	325 lbs.	\$2799

POTATO Planter, Hiller & Digger



This unique implement will do all three tasks with the greatest of ease. Attach the seat and rear cover board and plant your potatoes with ease. In mid-season bolt on the 18" sweep and hill the potatoes. At harvest time, go down the centre of the row with the sweep and watch the potatoes roll out on either side. Works like a dream.

- * **Cat. 1 3 Pt. hitch**
- * **HP Requirements: 25**

MODEL	DESCRIPTION	LIST PRICE
1700166	3-in-1 Potato Planter, Hiller and Digger	\$829

3 PT. MOLDBOARD PLOWS



MPH214



MPH112

as shown with optional
MP080017 depth gauge kit,
MP080018 coulter blade kit

The Howse Implement Co. 3 Pt. hitch Cat.1 moldboard plows are ideal for the small acreage plowing. For sub compact and compact tractors. Made from heavy 1" x 4" steel bar with replaceable shares and moldboards. Optional depth control and coulter kits available.

MODEL	DESCRIPTION	WEIGHT	LIST PRICE
MPH112	One 12" Bottom Plow	290 lbs.	\$559
MPH114	One 14" Bottom Plow	300 lbs.	\$579
MPH214	Two 14" Bottom Plow	490 lbs.	\$975
MPH216	Two 16" Bottom Plow	520 lbs.	\$999

OPTIONS:

MODEL	DESCRIPTION	LIST PRICE
MP080017	Depth Gauge Kit	\$105
MP080018	Coulter Blade Kit	\$125

One Coulter Blade Kit Required per Bottom

SINGLE SHANK RIPPERS



WORKSAVER offers the following tillage equipment for customers with compact or smaller horsepower tractors. All of this equipment is shear bolt protected.

MODEL	DESCRIPTION	WEIGHT	LIST PRICE
ER30	Economy ripper with reversible point shear bolt protected Cat. 0 and 1, 3 Pt. hitch 15 to 25 HP max.	66 lbs.	\$359
MBP36	Economy middle buster with 15" shovel shear bolt protected Cat. 0 and 1, 3 Pt. hitch 15 to 25 HP	77 lbs.	\$369
R130	Heavy duty single shank ripper with 30" shank on a 31" frame Cat. 1 and 2, 3 Pt. hitch reversible point, shear bolt protected	218 lbs.	\$949

SUB-SOILERS

3 Pt. Hitch



These quality constructed two and three shank sub-soilers are constructed of 5" x 7" heavy wall steel tubing for maximum strength. The shanks are 1-1/4" thick with 28" or 32" height.

MODEL	SHANKS	WEIGHT	FRAME LENGTH	SHANK SPACING	LIST PRICE
2S2860T1	(2) 28"	609 lbs.	60"	52"	\$2999
2S2880T1	(2) 28"	655 lbs.	80"	72"	\$3099
3S3290T1 Dble. Bar	(3) 32"	1264 lbs.	90"	Adjustable	\$4999

When using sub-soilers in rocky conditions, warranty will be considered for manufacturers defects only, not for damage from sub-terranean obstacles.

UTILITY PRODUCTS

3 Pt. Hitch
Utility Carrier
Pallet Forks
Crane Boom

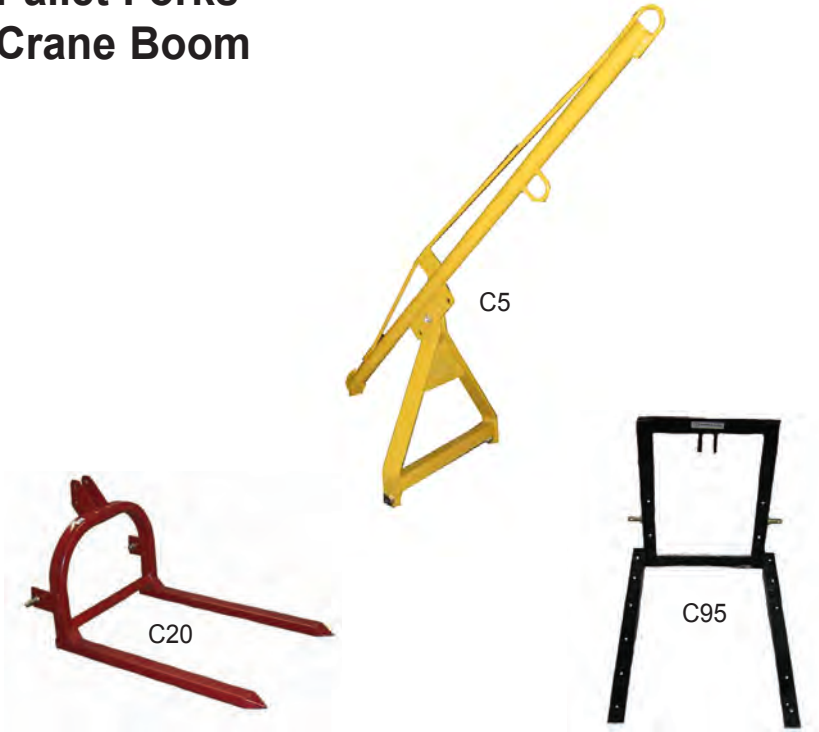

These Category 1, 3 Pt. hitch utility products include:

The C95 3 Pt. **Platform Carrier Frame** is a multi-use carrier, simply add boards or steel plate for desired width to pre-drilled bolt holes in the angular steel welded frame.

The C20 3 Pt. **Pallet Fork** is for moving pallets or crates, ideal for fruit or vegetable operations. 43" long tubular forks spaced 30-1/2" apart.

The C5 3 Pt. bolt together standard duty crane boom is rated at 500 lbs. with a 70" horizontal reach from lower 3 Pt. lift pins

MODEL	DESCRIPTION	CAPACITY	WEIGHT	LIST PRICE
C95	Platform carrier frame 24" Wide x 37" long x 2-1/2" angle	500 Lbs.	68 lbs.	\$239
C20	Pallet forks, Cat. 1, 3 pt. hitch.	2000 Lbs.	119 lbs.	\$485
C5	Standard Duty Boom Crane 500 lb.	70" reach	65 lbs.	\$199

POST HOLE DIGGERS

3 Pt. PTO & Hydraulic



500WS PHD



720 PHD



624H PHD



Fish Tail Point



102165
Parking stand



925 PHD



DFK50-70-90



924H PHD



824H PHD

POST HOLE DIGGERS

3 Pt. PTO & Hydraulic



WORKSAVER

- * Heavy duty tubular steel stock on yoke & booms
- * Large 2" round output shaft has two bolt auger connection
- * Shear pin protected & shielded PTO drivelines.
- * Down force kits available
- * 3 position boom adjustment on PTO models
- * 5 year limited gearbox warranty
- * Trouble free tapered roller bearings & spring loaded seals
- * Choose from a large selection of 9", 12" by 30" long, single flight and 6" to 30' x 42" long, double flight all with Fish Tail auger points
- * Parking Stands available.
- * 924HC/EURO fits directly onto ALO loaders
- * Model 624H Includes hydraulic hoses.
- * Models 724H, 824H, 924H, 924HC/EURO. Do Not Include hydraulic hoses

MODEL	GEAR RATIO	HITCH SIZE	AUGER LENGTH	AUGER USAGE	WEIGHT	LIST PRICE
3 PT. HITCH 540 RPM PTO						
300	3:1	Cat. 0	30"	9" - 12"	149 lbs.	\$749
500WS	3:1	Cat. 1 and 2	42"	6" - 12"	160 lbs.	\$759
720	3.18:1	Cat. 1 and 2	42"	6" - 24"	206 lbs.	\$979
925	4.1:1	Cat. 1 and 2	42"	6" - 30"	210 lbs.	\$1225
HYDRAULIC DRIVE, Requires 10-20 gpm @ 1500-3000 psi						
624H	3Pt. hitch	Cat 1 & 2 (inc. hyd hoses)		6" - 24"	182 lbs.	\$1819
724H		Loader (bolt-on side plate)		6" - 24"	127 lbs.	\$1665
824H		Loader (clamp-on)		6" - 24"	196 lbs.	\$1825
924H		Skid steer quick attach mount		6" - 24"	210 lbs.	\$1720
924HC		ALO loader mount		6" - 24"	220 lbs.	\$1679

AUGERS

MODEL	DESCRIPTION	WEIGHT	LIST PRICE
9SF	9" Single flight 30" long	25 lbs.	\$169
12SF	12" Single flight 30" long	28 lbs.	\$175
6HDDF	6" Double flight 42" long	32 lbs.	\$209
9HDDF	9" Double flight 42" long	47 lbs.	\$239
12HDDF	12" Double flight 42" long	54 lbs.	\$269
14HDDF	14" Double flight 42" long	76 lbs.	\$325
18HDDF	18" Double flight 42" long	98 lbs.	\$499
24HDDF	24" Double flight 42" long	128 lbs.	\$645
30HDDF	30" Double flight 42" long	190 lbs.	\$819

OPTIONS:

MODEL	DESCRIPTION	WEIGHT	LIST PRICE
170705	12" Auger Extension (extends 42" augers to 54")	16 lbs.	\$185
DFK50	*Down force kit for model 500WS	39 lbs.	\$469
DFK70	*Down force kit for model 720, 624H	40 lbs.	\$469
DFK90	*Down force kit for model 925	42 lbs.	\$469
	*Kit contains hydraulic cylinder & hoses		
102160	Parking stand for model 300	11 lbs.	\$109
102165	Parking stand for model 500/720	12 lbs.	\$119
102170	Parking stand for model 925	13 lbs.	\$129

Weights indicated are base machine weight, not shipping weight

POST DRIVERS

3 Pt. Hitch



Installing new fencelines? Replacing old ones? **WORKSAVER** post drivers are built to last with quality features designed to improve operator convenience, versatility, production and performance in all kinds of conditions. Units come complete with a post holder.

WITH MANUAL ADJUSTMENT

	HPD16	HPD20	24 Series (HPD24SHC)
Maximum post size	7" x 9'	8 3/4" x 10'	11" x 10'
Impact at full stroke	32,000 lbs.	80,000 lbs.	110,000 lbs.
Impact at half stroke	16,000 lbs.	40,000 lbs.	55,000 lbs.
Minimum tractor size	22 HP PTO	35 HP PTO	50 HP PTO
Hitch Type	Cat. 1 and 2	Cat. 1 and 2	Cat. 1 and 2
LIST PRICE	\$3125	\$4265	n/a w/manual adjust

WITH HYDRAULIC ADJUSTMENT

	HPD16SHC	HPD20SHC	HPD24SHC
Min Hyd. requirements	3 - 4 GPM	6 - 8 GPM	12 GPM
Tilt Adjustment	- Front/Back - Side/Side	17° each way from vertical 20° each way from vertical	
# of Cylinders	2 - 3" x 6"	2 - 3" x 6"	2 - 3" x 6"
LIST PRICE	\$5289	\$6429	\$7749

POST DRIVERS

Skid Steer



Installing new fence lines? Replacing old ones? Setting post for livestock pens, feedlots, vineyards, etc. save time and eliminate backbreaking labour with a **WORKSAVER** Skid steer Post Driver.

WITH MANUAL ADJUSTMENT & UNIVERSAL STYLE QUICK ATTACH BRACKETS

	HPD16MSS	HPD20MSS
Maximum post size:	7" x 9'	8-3/4" x 10'
Impact at full stroke:	32,000 lbs.	80,000 lbs.
Impact at half stroke:	16,000 lbs.	40,000 lbs.
Minimum hydraulic req.:	3-4 GPM	6-8 GPM
Tilt Adjustment:	Front/back 10° each way from vertical Side/side 17° each way from vertical	
Weight:	653 lbs.	803 lbs.
LIST PRICE	\$4009	\$5049

WITH HYDRAULIC ADJUSTMENT & UNIVERSAL STYLE QUICK ATTACH BRACKET

	HPD16HSS	HPD20HSS	HPD24HSS
Maximum post size:	7" x 9'	8-3/4" x 10'	11" x 10'
Impact at full stroke:	32,000 lbs.	80,000 lbs.	110,000 lbs.
Impact at half stroke:	16,000 lbs.	40,000 lbs.	55,000 lbs.
Min Hyd. requirements:	3-4 GPM	6-8 GPM	12 GPM
Tilt Adjustment:	Front/Back 17° each way from vertical Side/Side 20° each way from vertical		
Weight:	1062 lbs.	1212 lbs.	1404 lbs.
LIST PRICE	\$6139	\$7279	\$8599

NOTE: HSS & MSS models include special hydraulic valve. Return line package required as extra, please advise model of skid steer when ordering post driver.



AMAZONE

The CATROS compact disc harrows from AMAZONE make work go by twice as quick ! Being easy to pull, these machines allow for high speed travelling but still leave a top class quality of work.

High work rates, low fuel consumption and low wear costs are the special strengths of the CATROS. They are ideally suited for a fast, shallow and intense mixing stubble work and operate blockage free even in high amounts of stubble. The incorporation of straw and stubble, the loosening up of grassland, seedbed preparation and the incorporation of organic manures offers additional flexibility in use. The broad range includes mounted and trailed machines in working widths from 3 meters to 7.5 meters.



AMAZONE

PACKERS 3 Pt.



- * Designed for 40 to 80 HP tractors
- * 3 Pt hitch Cat. I - 6', Cat. I / II - 8' & 12'
- * Heavy duty 4" square tube steel main frame
- * 16" cast iron sprocket packer wheels
- * Heavy duty 1-1/8" gang axle with ball bearings
- * Parking stands

MODEL	DESCRIPTION	WEIGHT	LIST PRICE
BCP1816	6' working width packer	1035 lbs.	\$2849
BCP2416	8' working width packer	1300 lbs.	\$3669
BCP3616	12' working width packer	1885 lbs.	\$5419

DISC HARROWS

"THE" Series

3 Pt. Hitch



The Monroe Tufline THE series 3 Pt. hitch disc harrows are designed for 25HP to 35HP tractors. Available in 5'6", 6'4" & 6'8" cutting widths with category I 3 Pt. hitch. 3" square tube frame, 1" square high strength steel gang axles, 7 1/2" or 9" blade spacing & 18" notched disc blades. Sealed gang bearings, lever adjusting gang angles. Optional blade scrapers are available.

- * 3" Square steel tube frame
- * Cat I, 3 Pt. hitch
- * 18" Notched disc blades
- * 7 1/2" or 9" blade spacing
- * Adjustable gang angle
- * 1" High strength gang axle
- * Sealed flange mounted gang ball bearings

MODEL	# BLADES	BLADE SPACING	WIDTH	WEIGHT	LIST PRICE
1THE71618BF	16	7 1/2"	5'6"	659 lbs.	\$1829
1THE72018BF	20	7 1/2"	6'8"	732 lbs.	\$2059
1THE91618BF	16	9"	6'4"	718 lbs.	\$1899
1THE971818BF	18	9" Front 7 1/2 Rear	6'8"	736 lbs.	\$1999

OPTIONAL SCRAPER KITS

MODEL	FITS MODEL	WEIGHT	LIST PRICE
RSK716L	1THE716	65 lbs.	\$369
RSK720L	1THE720	82 lbs.	\$379
RSK916L	1THE916	72 lbs.	\$429
RSK9718L	1THE9718	80 lbs.	\$399

OFFSET DISC "TLO" Series 3 Pt. Hitch



The Monroe Tufline TLO series 3 Pt. hitch offset discs are designed for 25 to 75HP tractors. Available in 4'6" to 8'4" cutting widths with category I or II 3 Pt. hitch. Units come with 3" square tube frame, 1 1/8" square high strength steel gang axles, 9" blade spacing, 20" disc blades & sealed gang bearings. Unit also has pin adjusting gang angles and front to rear leveling for side draft control. Optional blade scrapers are available.

- * 3" Square steel tube frame
- * Cat I or II, 3 Pt. hitch
- * 1 1/8" High strength gang axle
- * 9" Blade spacing
- * Adjustable gang angle
- * Pressure control levelling
- * 20" Notched disc blades
- * Sealed gang ball bearings

MODEL	# BLADES	CUTTING WIDTH	WEIGHT	LIST PRICE
TLO91220	12	4'6"	710 lbs.	\$2079
TLO91420	14	5'3"	996 lbs.	\$3029
TLO91620	16	6'	1101 lbs.	\$3259
TLO91820	18	6'8"	1185 lbs.	\$3489
TLO92020	20	7'6"	1250 lbs.	\$3669
TLO92220	22	8'4"	1318 lbs.	\$3869

OPTIONAL SCRAPER KITS

MODEL	FITS MODEL	WEIGHT	LIST PRICE
SLO912	TLO912	144 lbs.	\$579
SLO914	TLO914	156 lbs.	\$609
SLO916	TLO916	192 lbs.	\$639
SLO918	TLO918	207 lbs.	\$679
SLO920	TLO920	224 lbs.	\$729
SLO922	TLO922	250 lbs.	\$769

DISC HARROWS

"TW6" Series

Pull Type



The TW6 Series Tandem Discs are heavy engineered discs designed for primary tillage applications. The TW6 is available in 10', 12', 13', & 15' working widths. Constructed of heavy 6" x 4" and 4" square steel frames. Blade spacing available in 9" or 10-1/2" with 24" plain or notched 6 mil disc blades on 1-1/2" cold drawn square gang axles. Gangs are mounted with triple sealed ball bearings (optional regreaseable bearings available) in a ductile cast trunnion housing with hi-strength tube style or shock flex (c-shank) gang hangers. All units offer adjustable gang cutting angle, front to rear leveling system and depth control.

- * Heavy 6" x 4" and 4" Square Steel Frame
- * Dual Wheel Carriage with 4 – 9.5L x 15 6 Ply Implement tires
- * Front to Rear Leveling System
- * Depth Control System
- * Adjustable Gang Cutting Angle
- * 1-1/2" Square cold Drawn Steel Gang Axle
- * 9" or 10-1/2" Blade Spacing
- * 24" 6 mil Plain or Notched Disc Blades (Customer Choice)
- * Triple Sealed Trunnion Mount Gang Ball Bearings
- * Available with Tube Style or Shock Flex Gang Hangers
- * Includes Implement Tongue Jack, Safety Chain,
- * Includes 4"X 8" Hydraulic Cylinder, Set of Hydraulic Hoses
- * Options Available
 - Regreaseable Gang Ball Bearings
 - Heavy Adjustable Blade Scrapers

DISC HARROWS



"TW6" Series

Pull Type

9" SPACING

MODEL	BLADES	# OF BRGS	TUBE WIDTH	TUBE WT. (LBS)	TUBE LIST	SHOCK FLEX WT. (LBS)	SHOCK FLEX LIST
TW692824	(28) 24"	8	10' 6"	4401 lbs	\$12,469	4869 lbs	\$13,459
TW693224	(32) 24"	8	12'	4794 lbs	\$13,489	5212 lbs	\$14,499
TW693624	(36) 24"	12	13' 4"	5158 lbs	\$14,939	5576 lbs	\$16,469
TW694024	(40) 24"	12	15'	5539 lbs	\$15,899	5975 lbs	\$17,419

10-1/2" SPACING

MODEL	BLADES	# OF BRGS	TUBE WIDTH	TUBE WT. (LBS)	TUBE LIST	SHOCK FLEX WT. (LBS)	SHOCK FLEX LIST
TW6102424	(22) 24"	8	10' 6"	4279 lbs	\$11,519	4883 lbs	\$12,539
TW6102824	(28) 24"	8	12'	4570 lbs	\$12,969	4886 lbs	\$14,489
TW6103224	(32) 24"	12	13' 4"	4970 lbs	\$13,609	5324 lbs	\$15,829
TW6103624	(36) 24"	12	15'	5319 lbs	\$15,799	5737 lbs	\$17,319

TW6 SERIES SCRAPER KITS

9" SPACING

MODEL	USED ON	WEIGHT (LBS.)	LIST PRICE
SK928/6	TW6928	320	\$999
SK932/6	TW6935	353	\$1099
SK936/6	TW6936	441	\$1199
SK940/6	TW6940	479	\$1289

10-1/2" SPACING

MODEL	USED ON	WEIGHT (LBS.)	LIST PRICE
SK1024/6	TW61024	298	\$889
SK1028/6	TW61028	326	\$1019
SK1032/6	TW61032	406	\$1109
SK1036/6	TW61036	448	\$1199

TW6 SERIES OPTIONS:

MODEL	DESCRIPTION	LIST PRICE
T703-18	(Pair) Outrigger kit (Furrow Filler)	\$229
11476	Balk breaker with point	\$219
13188	Regreasable gang ball bearings	\$29

OFFSET DISC "42" Series



- * Includes 4" x 8" Hydraulic Cylinder with hydraulic hoses (less coupler plugs)
- * Implement Tongue Jack, Safety Chain, SMV Sign
- * Standard with Notched Disc Blades
- * HP Requirements: 60-120 (Approx. 10 HP per Ft.)
- * Tongue and yoke system for side draft
- * Gang angles adjust by turnbuckles
- * Triple sealed ball bearings in trunnion mount
- * Dual wheels on all models includes 9.5L x 15 6 ply implement tires
- * 24" and 26" disc blades - 1/4" thick
- * Shock flex gang hangers for rocky soil conditions
- * 6" x 4" heavy wall tube frame
- * 1-1/2" RC square cold drawn axle
- * Front and rear levelling system

OPTIONAL EQUIPMENT

- * Blade scrapers, Plain (Smooth) Blades, Regreasable Gang Bearings, Furrow Filler Kit (see page 137 OPTIONS)

9" SPACING

MODEL	BLADES	# OF BRGS	WIDTH	SHOCK FLEX WT. (LBS)	SHOCK FLEX LIST
42/91824	(18) 24"	8	6' 8"	3907	\$11,709
42/91826	(18) 26"	8	6' 8"	4038	\$12,089
42/92024	(20) 24"	8	7' 8"	4000	\$12,069
42/92026	(20) 26"	8	7' 8"	4166	\$12,485
42/92224	(22) 24"	8	8' 4"	4250	\$12,439
42/92226	(22) 26"	8	8' 4"	4396	\$12,899
42/92424	(24) 24"	8	9'	4540	\$12,745
42/92426	(24) 26"	8	9'	4672	\$13,250
42/92824	(28) 24"	12	10' 4"	4868	\$14,099
42/92826	(28) 26"	12	10' 4"	5047	\$14,699
42/93224	(32) 24"	12	12' 3"	5161	\$15,529
42/93226	(32) 26"	12	12' 3"	5344	\$16,209
42/93624	(36) 24"	14	13' 3"	5311	\$16,979
42/93626	(36) 26"	14	13' 3"	5655	\$17,739

Add "SF" to Model # when ordering disc equipped with Shock Flex Gang Hangers

OFFSET DISC "42" Series



10-1/2" SPACING

MODEL	BLADES	NO. OF BRGS.	WIDTH OF CUT	SHOCK FLEX WGT. (LBS.)	SHOCK FLEX LIST
42/101824	(18) 24"	8	8'	4002	\$11,859
42/101826	(18) 26"	8	8'	4010	\$12,239
42/102024	(20) 24"	8	9'	4228	\$12,079
42/102026	(20) 26"	8	9'	4360	\$12,499
42/102224	(22) 24"	8	9' 10"	4394	\$12,479
42/102226	(22) 26"	8	9' 10"	4526	\$12,949
42/102424	(24) 24"	8	10' 6"	4649	\$13,089
42/102426	(24) 26"	8	10' 6"	4807	\$13,599
42/102824	(28) 24"	12	12'	5164	\$15,245
42/102826	(28) 26"	12	12'	5314	\$15,835
42/103224	(32) 24"	12	13' 9"	5278	\$15,669
42/103226	(32) 26"	12	13' 9"	5500	\$16,345

42 Series SCRAPER KITS

9" SPACING

MODEL	USED ON	WEIGHT (LBS.)	LIST PRICE
OSK42/918	42/918	276	\$699
OSK42/920	42/920	294	\$769
OSK42/922	42/922	325	\$819
OSK42/924	42/924	359	\$859
OSK42/928	42/928	460	\$1019
OSK42/932	42/932	527	\$1149
OSK42/936	42/936	580	\$1239

10-1/2" SPACING

MODEL	USED ON	WEIGHT (LBS.)	LIST PRICE
OSK42/1018	42/1018	277	\$729
OSK42/1020	42/1020	303	\$789
OSK42/1022	42/1022	330	\$819
OSK42/1024	42/1024	352	\$859
OSK42/1028	42/1028	410	\$1049
OSK42/1032	42/1032	527	\$1119

42 SERIES OPTIONS:

MODEL	DESCRIPTION	LIST PRICE
T703-1/2-20	Furrow Filler	\$120
13188	Additional charge for regreasable gang brgs. 1-1/2"	\$29

TO PRICE AN OFFSET DISC MAKE SURE YOU HAVE PRICED:

1. Scraper kit (If Required)
2. Any applicable options from the option list
3. Remember your spacing - 9" or 10-1/2" available
4. Order blades plain, notched, or a combination

TRACTOR CANOPIES JUNIOR

BARE-Co



B3580 Shown

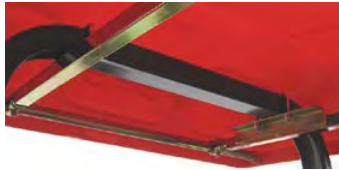

B3581 Shown

The **BARE-Co** junior canopy is moulded from virtually indestructible flexible U.V. stabilized polyethylene. The canopy is 34" wide x 47" long and is designed moulded to hug modern hoop type ROPS frames. Available in standard colours, with two mounting kits to fit most compact & sub-compact tractors ROPS frames.

MODEL	DESCRIPTION	WEIGHT	PRICE
B2581	White Canopy	20 lbs.	\$349
B2582	Green Canopy	20 lbs.	\$349
B2583	Orange Canopy	20 lbs.	\$349
B2584	Blue Canopy	20 lbs.	\$349
B2585	Red Canopy	20 lbs.	\$349
B2586	Yellow Canopy	20 lbs.	\$349
B3580	Mounting Kit Mounts canopy to HOOP, CURVED or SQUARE TOP Both rigid or folding up to 30" wide with leg thickness up to 3-3/16" x 2"	17 lbs.	\$160
B3581	Mounting Kit Mounts the canopy OVERWIDTH ROPS frames with a width of more than 30" wide, with a leg thickness from 2" x 2" to 2" x 4"	13 lbs.	\$120

TRACTOR CANOPIES SENIOR

BARE-Co



B3600 Shown

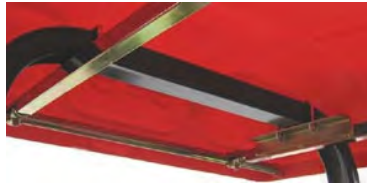

B2565 Shown

The **BARE-Co** standard canopy is moulded from virtually indestructible flexible U.V. stabilized polyethylene. The canopy is 45" wide x 60" long and is designed moulded to hug modern hoop type ROPS frames. Available in standard colours, with three mounting kits to fit most types of ROPS frames.

MODEL	DESCRIPTION	WEIGHT	PRICE
B2570	White Canopy	29 lbs.	\$429
B2571	Green Canopy	29 lbs.	\$429
B2572	Orange Canopy	29 lbs.	\$429
B2573	Blue Canopy	29 lbs.	\$429
B2580	Red Canopy	29 lbs.	\$429
B3600	Mounting Bracket Mounts the canopy to any folding or rigid hoop type ROPS frame up to 41-1/2" wide, with leg thickness up to 3-3/16" x 2"	17 lbs.	\$169
B2565	Mounting Bracket Mounts the canopy to overwidth ROPS frames, crossbar or leg width more than 41-1/2", leg thickness from 2" x 2" to 2" x 4"	13 lbs.	\$135
B4620	Mounting Bracket Mounts the canopy to ROPS frames up to 41-1/2" wide with leg thicknesses of 4" x 4", 5" x 2" or 6" x 2"	21 lbs.	\$245

QUICK HITCHES



WORKSAVER quick hitches are built for fast, safe and easy connection and disconnection of 3 Pt. implements. The **WORKSAVER** quick hitches fit most Category 1, 2 and 3 Pt. hitch tractors.

- A** Inside Hooks
- B** Outside Hooks
- C** Centerline Distance of lower pin to upper pin
- D** Pocket sized for 1-7/16" pins or bushings

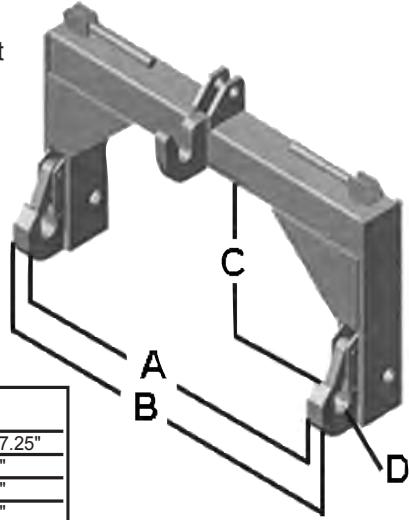

QUICK HITCH SPECIFICATIONS			
MODEL	A	B	C
QH101	25.75"	29.50"	14.50" - 17.25"
QH102	32.75"	36.25"	14.88"
QH107HD	32.50"	37.75"	14.88"
QH1023	38.25"	43.15"	18.88"
QH103	38.25"	43.50"	18.88"
QH106N	32.63"	37.00"	19.00"

- * High strength tubing for torsional strength
- * Over-center spring loaded latch mechanism provides positive lock yet easy equipment release
- * Solid frame cut parts for long life
- * Reinforced at known wear points
- * Non-rotating adapter bushings for wear resistance
- * Rubber handle grips on latch handles
- * Tapered top hitch point bracket for easy hook-up
- * Includes one set adapter bushings with QH101, QH102, QH107HD

MODEL	DESCRIPTION	WEIGHT	LIST PRICE
QH101	Cat. 1 (up to 50 HP)	76 lbs.	\$359
QH102	Cat. 2 (up to 100 HP)	134 lbs.	\$499
QH107HD	Cat. 2 HD (up to 150 HP)	160 lbs.	\$599
QH1023	Cat. 2 to Cat. 3 Allows use of Cat. 3 implements on tractors with Cat. 2, 3 Pt hitch	185 lbs.	\$709
QH103	Cat. 3 (up to 225 HP)	182 lbs.	\$709
QH106N	Cat. 3 Narrow (up to 225 HP)	176 lbs.	\$709

HYDRAULIC TOP LINK



TLC3110

MODEL	DESCRIPTION	LIST PRICE
TLC3110	Hydraulic top link Cat. II, 3" bore x 10" stroke, 1-1/4" dia. shaft 21" closed, 1/2" ports, 2500 PSI working pressure	\$339

LOADER BRACKETS QUICK ATTACH



Euro/Global/Alo to Skid Steer Adaptor



832550

WorkSaver is introducing a "NEW" interfacing adaptor, designed to allow the use of skid steer attaching system to be used on loaders with the Euro style quick attach system. This all welded design, features plated handles, springs and lock pins. In addition, the customer can easily switch attachments between a skid steer loader and a tractor loader.

MODEL	DESCRIPTION	WEIGHT	PRICE
832550	Euro to skid steer adaptor	110 lbs.	\$729

Weld-On Skid Steer Bracket

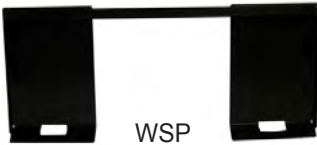

WSP

Weld-On Euro/Global/Alo Quick Attach Brackets



Left Hand

ALO1

Right Hand

The WSP plate simply welds to existing attachment i.e. bucket, stone fork etc. to convert to "Universal" skid steer quick attach mounting.

MODEL	DESCRIPTION	WEIGHT	PRICE
WSP	Weld-on plate	46 lbs.	\$159
ALO1	2 pc. Weld-on Euro/Global/Alo quick attach brackets	36 lbs.	\$139

Universal Skid Steer Quick Attach Brackets

This plate can u-bolt to any attachment to mount to skid steer universal quick attach



MODEL	DESCRIPTION	WEIGHT	PRICE
831110	Universal skid steer quick attach to u-bolt implement plate	95 lbs.	\$289

ROTARY BROOMS SKID STEER MOUNT



The WORKSAVER skid steer hydraulically driven rotary broom fits any make and model of skid steer with universal skid steer quick attach mounting. Hydraulic motor rated @ 16GPM continuous operation for maximum brush speed. Optional manual or hydraulic angling kit available. All hydraulic hoses sheathed and routed through integral loops for maximum protection. Flat-faced "connect under pressure" hydraulic couplers standard

- * **Universal skid steer quick attach mounting**
- * **16 GPM hydraulic motor**
- * **4.36 / 1 chain drive ratio to broom for excellent torque**
- * **Heavy duty #60 drive roller chain**
- * **Parking stands**
- * **Step-through mount design for easy in/out of skid steer cab**
- * **Greaseable pivot points for long life**
- * **32" diameter poly or poly/wire brush**
- * **Optional manual or hydraulic angle adjustment kit available**

MODEL	DESCRIPTION	WEIGHT	PRICE
SSMB325P	5'/60" Wide Rotary Broom with Poly Brush	630 lbs.	\$5979
SSMB325PW	5'/60" Wide Rotary Broom with Poly/Wire Brush	630 lbs.	\$5979
SSMB326P	6'/72" Wide Rotary Broom with Poly Brush	730 lbs.	\$6365
SSMB326PW	6'/72" Wide Rotary Broom with Poly/Wire Brush	730 lbs.	\$6365
SSMB327P	7'/84" Wide Rotary Broom with Poly Brush	830 lbs.	\$7019
SSMB327PW	7'/84" Wide Rotary Broom with Poly/Wire Brush	830 lbs.	\$7019

OPTIONS:

	DESCRIPTION	LIST PRICE
610702	Manual Angle Adjustment Kit	\$149
610703	Hydraulic Angle Adjustment Kit	\$469
	inc'ds hyd. cylinder & hoses, less tips	
610940	Hydraulic Angle Adjustment Kit with Electric Hydraulic Solenoid control.	\$1559
	For skid steer rotary Brooms used on units equipped with only one set of remotes, inc'ds hyd. cylinder, hoses, valve, & flat faced couplers, Factory Installed	

ROTARY BROOMS

3 Pt. HITCH PTO



The WORKSAVER 3 Pt. hitch 540 RPM PTO Rotary Broom mounts to any tractor with 540 RPM PTO. Keep your tractor and sweeper busy all year sweeping snow, dirt, thatch, leaves and other debris. Sweeps forward and can wind-row debris, to the front, right or left. If you reverse broom rotation, pulling action cleans thatch with out damaging grass. Mechanical brush drive, with optional manual angle, 30 degrees right or left, or optional hydraulic angle available. Height adjustment chains maintains even operating position. 32" diameter broom is available in poly, or combo 50/50 poly/wire. A double gearbox drive is used for smooth power transmission and low maintenance. Top "T-Shaft" gearbox allows for easy reversal of brush rotation.

- * **Cat. 1, 3 Pt. hitch**
- * **540 RPM PTO**
- * **Optional Manual or hydraulic angle**
30 degrees right or left
- * **Height adjustment chains**
- * **32" diameter brush**
- * **Available in Poly, or 50/50 Poly/Wire brush**
- * **Double gearbox drive**
- * **Top "T-Shaft" gearbox allows easy reversal of brush rotation**

MODEL	DESCRIPTION	WEIGHT (LBS.)	LIST PRICE
RMB325P	5' Wide rotary broom with poly brush	640 lbs.	\$5579
RMB325PW	5' Wide rotary broom with poly/wire brush	640 lbs.	\$5579
RMB326P	6' Wide rotary broom with poly brush	740 lbs.	\$5845
RMB326PW	6' Wide rotary broom with poly/wire brush	740 lbs.	\$5845
RMB327P	7' Wide rotary broom with poly brush	840 lbs.	\$6379
RMB327PW	7' Wide rotary broom with poly/wire brush	840 lbs.	\$6379

OPTIONS:

MODEL	DESCRIPTION	LIST PRICE
610702	Manual Angle Kit	\$149
610703	Hydraulic Angle Kit with hoses	\$469

WWW.FARMFLEET.COM

23703 Wellburn Rd.
St. Marys, ON N4X 1C6
Tel: 519-461-1499
Fax: 519-461-1599

839 McLellans Brook Rd.
New Glasgow, NS B2H 5C5
Tel: 902-755-0858
Fax: 902-755-2362

Email: farmfleet@execulink.com



• Your Local Farm-Fleet Dealer •

